

PC600 Series Terminal

User's Guide

**THIS EQUIPMENT COMPLIES WITH FCC REQUIREMENTS
PURSUANT OF PART-15**

This device complies with Part 15 of the FCC Rules. Operation is subject to the following two conditions: (1) this device may not cause harmful interference, and (2) this device must accept any interference received, including interference that may cause undesired operation.

WARNING: Changes or modifications to this product not expressly approved by the party responsible for compliance could void the user's authority to operate this equipment.

NOTE: This equipment has been tested and found to comply with the limits, pursuant to Part 15 of the FCC Rules. These limits are designed to provide reasonable protection against harmful interference in a business installation. This equipment generates, uses, and can radiate radio frequency energy and, if not installed and used in accordance with the instructions, may cause harmful interference to radio communications. However, there is no guarantee that interference will not occur in a particular installation. If this equipment does cause harmful interference to radio or television reception, which can be determined by turning the equipment off and on, the user is encouraged to try to correct the interference by one or more of the following measures:

- Reorient or relocate the receiving antenna.
- Increase the separation between the equipment and receiver.
- Connect the equipment into an outlet on a circuit different from that to which the receiver is connected.
- Consult the dealer or an experienced radio TV technician for help.

**This Class A digital apparatus complies with Canadian ICES-003.
Cet appareil numérique de la classe A est conforme à la norme NMB-003 du
Canada.**

Lathem Time Corporation
200 Selig Drive, SW,
Atlanta, GA 30336
404-691-0405

www.lathem.com

Copyright © 2010 Lathem Time Corporation. All rights reserved.

Revised 05-14-2013

Document number: USG0096 Rev. C

One-Year Limited Warranty

Lathem warrants the hardware products described in this guide against defects in material and workmanship for a period of one year from date of original purchase from Lathem or from an authorized Lathem reseller. The conditions of this warranty and the extent of the responsibility of Lathem Time Corporation ("Lathem") under this warranty are listed below.

1. This warranty will become void when service performed by anyone other than an approved Lathem warranty service dealer results in damage to the product.
2. This warranty does not apply to any product which has been subject to abuse, neglect, or accident, or which has had the serial number altered or removed, or which has been connected, installed, adjusted, or repaired other than in accordance with instructions furnished by Lathem.
3. This warranty does not cover dealer labor cost for removing and reinstalling the machine for repair, or any expendable parts that are readily replaced due to normal use.
4. The sole responsibility of Lathem under this warranty shall be limited to repair of this product, or replacement thereof, at the sole discretion of Lathem.
5. If it becomes necessary to send the product or any defective part to Lathem or any authorized service dealer, the product must be shipped in its original carton or equivalent, fully insured with shipping charges prepaid. Lathem will not assume any responsibility for any loss or damage incurred in shipping.
6. **WARRANTY DISCLAIMER AND LIMITATION OF LIABILITY:** Except only the limited express warranty set forth above, the products are sold with no expressed or implied warranties of any kind, and the implied warranties of merchantability and fitness for a particular purpose are hereby expressly disclaimed. No warranties are given with respect to products purchased other than from Lathem or an authorized Lathem reseller and any such products are purchased "as is, with all faults." In no event will Lathem be liable for any direct, indirect, special, incidental or consequential damages arising out of or in connection with the delivery, use or inability to use, or performance of this product. In the event any limited remedy given herein shall be deemed to have failed of its essential purpose, Lathem's maximum liability shall be to refund the purchase price upon return of the product.
7. Proof of date of purchase from Lathem or an authorized Lathem reseller is required for warranty service on this product.
8. This Warranty grants specific legal rights. Additional legal rights, which may vary by locale, may also apply.
9. Should any difficulties arise with the performance of this product during warranty, or with any Lathem authorized service centers, contact Lathem Time.

Contents

Welcome	1
Package Contents	4
Install the PC600 Series Terminal.....	5
PayClock Online	7
Adding a PC600 series terminal.....	7
Step 1 - Adding the PC600 series terminal	7
Step 2 - Connect the Terminal to PayClock Online.....	8
Changing settings at the Terminal.....	8
How do I change the time zone?	9
How do I disable daylight savings?.....	9
How do I change the displays time format?.....	10
Changing settings from PayClock	10
How do I change the time zone?	10
How do I disable daylight savings?.....	10
How do I change the displays time format?.....	11
How do I disable PIN entry for all employees?	11
How do I disable Badge entry for all employees?	11
How do I disable amount entry for all employees?.....	12
How do I disable transfers for all employees?.....	12
PayClock Desktop	14
Adding a PC600 series terminal.....	14
How do I search from PayClock and add a PC600 series terminal?	14
How do I add a terminal to PayClock from the PC600?	15
Changing settings at the Terminal.....	17
How do I change the time source?	17
How do I change the time zone?	17
How do I disable daylight savings?.....	18
How do I change the displays time format?.....	18
How do I enable Live Sync from the terminal?	18
Changing settings from PayClock	19
How do I change the time source?	19
How do I change the time zone?	19

How do I disable daylight savings?	20
How do I change the displays time format?	20
How do I enable Live Sync from the PayClock software?	20
How do I disable PIN entry for all employees?	21
How do I disable Badge entry for all employees?	21
How do I disable amount entry for all employees?	22
How do I disable transfers for all employees?	22
Updating the Terminal.....	23
How do I update a terminal?	23
Polling the Terminal	23
How do I poll a terminal?.....	23
Activating Live Sync at the Terminal.....	24
How do I enable Live Sync from the PayClock software?	24
How do I enable Live Sync from the terminal?.....	25
Using the PC600 Series Terminal	26
PC600 Series Terminal Idle Screen	27
Employee Transactions using Badges	27
Clocking IN/Out	27
Department Transfers	27
Amount Entries	28
Viewing Totals	28
Employee Transactions using a PIN.....	28
Clocking IN/Out	28
Department Transfers	29
Amount Entries	29
Viewing Totals	29
Supervisor Transactions	30
Viewing Punches.....	30
Adding Punches	31
Viewing Totals	31
Send Message	32
Override Lockout	32
Settings - Set/Change PIN	33
Settings - View/Assign Badge	34
Administrator Functions	35
Device Information	35
Network Setup - Terminal Settings	35
Date/Time Setup - Date.....	38
Error Log.....	40
Relay Settings	41
⚠️ Reset	41
Troubleshooting the PC600 Series Terminal	43
General Troubleshooting	43

Index

A

Activating Live Sync	24
Add the terminal from PayClock	7
Adding a PC600 series terminal	14
Administrator Functions	35

C

Changing settings at the terminal	17
Changing settings from PayClock Desktop	19
Changing settings from PayClock Online	10

E

Employee transactions using a PIN	28
Employee transactions using badges	27

F

Features & Specifications	2
---------------------------	---

G

Getting Help	2
--------------	---

I

Install the PC600 Series Terminal	5
-----------------------------------	---

P

Package Contents	4
PC600 Series Terminal Idle Screen	27
Polling the Terminal	23

S

Supervisor Transactions	30
-------------------------	----

T

Troubleshooting	43
-----------------	----

U

Updating the Terminal	23
Using the PC600 Series Terminal	26

PC600 Series Troubleshooting	43
Appendix A - PC600 Series WAN Installation	45
PC600 Series WAN Installation.....	46
Appendix B - Bell Relay Connections	48
Appendix C - Access Relay Connections	53
Appendix D - Add/Edit/Delete Bell Events	55
Glossary of Terms	57
Index	59

Glossary of Terms

Time Source

The method in which the terminal gets its time, either the PayClock Server (the computer where the PayClock server is running) or NIST (the internet). This option is only available when the terminal is configured in Local mode for use with the PayClock Desktop product.

Live Sync

Allows the terminal to communicate with the computer in real-time. A terminal running in "Live Sync" mode doesn't have to be polled or updated. Punches are automatically added to the database, any changes will be detected and the terminal will automatically update itself. This option is only available when the terminal is configured in Local mode for use with the PayClock Desktop product.

Administrator

The PC600 series terminal has one administrator, the administrator function allows you review the device information, set up the network communications, set the time / date, review an error log and reset the terminal to the factory defaults.

Auto Poll

When a terminal is automatically polled, punch data is gathered and automatically added to the database allowing you to edit, export and report on the data. This option is only available when the terminal is configured in Local mode for use with the PayClock Desktop product.

Supervisor

An employee configured as a supervisor will have the ability at the terminal to view and edit employee punches, add new employees, send messages and override shift lockouts.

Editing a Bell Event

- From the PC600 touchpad press the Admin button. Enter the administrator PIN and press Enter.
- From the Administrator Main Menu press Relay Settings.
- The Relay Settings screen will display.
- Press Schedule under Signal Events. The Signal Event Schedule screen will display with all the schedule events.
- Select the desired Event. The Edit Event screen will display.
- Make the needed changes for the event.
- Press OK to save the changes. The edited programmed event will display in the list.
- When finished press the back ↵ button until you have returned to the home screen.

Deleting a Bell Event

- From the PC600 touchpad press the Admin button. Enter the administrator PIN and press Enter.
- From the Administrator Main Menu press Relay Settings.
- The Relay Settings screen will display.
- Press Schedule under Signal Events. The Signal Event Schedule screen will display with all the schedule events.
- Select the desired Event. The Edit Event screen will display.
- Press the Delete Event button. Press Yes at the confirmation message.
- The programmed event will be removed from the list.
- When finished press the back ↵ button until you have returned to the home screen.

Welcome

Reliability, functionality and ease of use are trademarks of the PayClock terminals. With the PC600 terminal, employees can use a badge or PIN to punch in and out, view messages or benefit time balances – it's that simple. In addition the PC600 contains an on-board relay which can be used to control bells/signaling devices, or security access.

The PayClock software and PC600 series terminals are the perfect solution for businesses that want to track employee time and automate payroll.

The PC600 series terminals connect to your network for communications with the time and attendance software. The terminal utilizes a powerful Windows CE based application and a touch-panel display for inputting data by employees, supervisors or administrators. The terminal validates that the employee is in the database before recording the transaction.

The terminal offers a large color LCD touch-panel that displays employee information along with an audio prompt. Upon a successful transaction with Live Sync enabled, the display will show the employee's name, total worked time, In / Out status and an audio/text prompt. Otherwise with Live Sync disabled, the display will show the employees name and Punch Accepted.

The PC600 series terminals can be used with the PayClock desktop product or the PayClock Online product. The PayClock desktop product is installed on a local pc and communicates with the terminal over the network. The PayClock Online product is in the cloud with the terminal communicating with PayClock Online over the internet.

Terminal Features and Specifications

- Windows CE 6.0 - The power of embedded Windows CE to provide fast and dependable operation.
- LCD Color Touch-Panel - Use the large easy to read touch-panel for set up and data entry.
- On-Board Relay - The on-board relay can be used to control bells/signal devices, or security access.
- Two Operating Modes - The terminal is functional with Live Sync enabled (online) or Live Sync disabled (offline). When Live Sync is enabled the terminal is real-time with the computer.
- PC600 series Idle Screen - Easy to read time/date screen will display after 2 minutes of inactivity on the terminal.
- User friendly design - Large easy to read touch-panel.
- Comprehensive support agreements minimize technical difficulties.
- Numerous Accessory options further enhance the functionality of your PC600 series terminal.

Accessories

A number of accessories are offered to further enhance your PayClock system. Visit <http://shop.lathem.com> to purchase additional accessories like the ones listed below.

- Badges
- Badge Racks
- Annual Support Agreements

Getting Help

You can access the help desk and answers to your issues in a number of different ways. In addition to resources within the PayClock software, assistance may be accessed online, via email, via telephone, or through your dealer. Don't forget annual support contracts are also offered.

PayClock Help

The Online Help allows you to search through an index of help topics to locate the answer you need. To launch the Help, click the Help button on the ribbon bar.

Appendix D - Add/Edit/Delete Bell Events

Up to 100 events can be programmed. Events consist of the time and the day of week the event will activate the relay.

Adding a Bell Event

- From the PC600 touchpad press the Admin button. Enter the administrator PIN and press Enter.
- From the Administrator Main Menu press Relay Settings.
- The Relay Settings screen will display.
- Press Signal under the Mode Settings. The button will change to blue identifying it's enabled.
- Press Schedule under Signal Events. The Signal Event Schedule screen will display.
- Press +Event. The Edit Event screen will display.
- Using the up and down arrow keys select the desired hour, minute and AM/PM for the bell event.
- Press the buttons for the desired days of the week, a check will display in the box identifying the day is selected.
- Press OK to save the event. The programmed event will display in the list.
- Continue adding the desired events.
- When finished press the back ↵ button until you have returned to the home screen.

Wiring for Door Access Control System

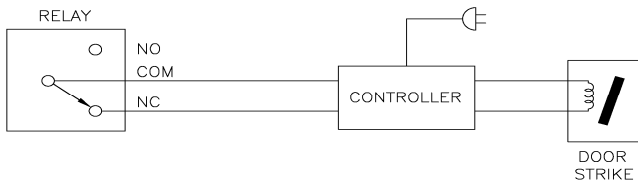

Door Strike Wiring For Door Strikes more than 1.5 Amps (Peak)

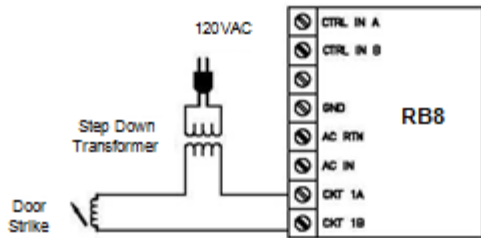
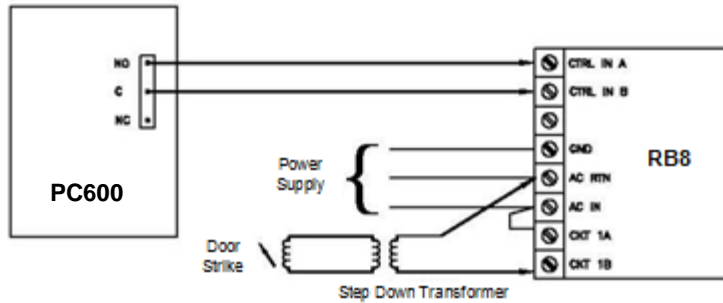

Door Strike Wiring For Door Strikes less than 1.5 Amps (Peak)

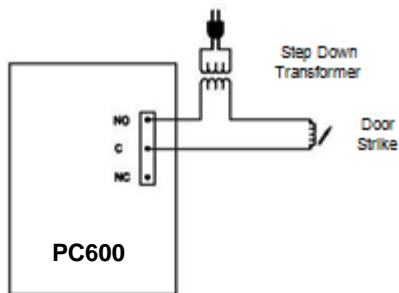

Troubleshooting

For answers to Frequently Asked Questions, refer to the Troubleshooting section of this User Guide.

Online and Email Support

Lathem.com provides access to numerous support resources that will allow you maximize your use of PayClock. Help may be accessed by visiting the following link: <http://support.lathem.com>

On the Support page, you may also submit a question through our online knowledgebase and one of our technicians will respond to your inquiry within 24 hours. Email support is free to all registered users.

Telephone Support

The help desk is available between the hours of 8am and 6pm ET Monday through Friday. Please call **(800) 241-4990** to speak with our help desk. You will receive free technical support for the first 30 days after your initial call. After that period, you may purchase an Annual Support Agreement, which will cover all calls for one year, or you may pay a per-call fee.

Annual Support Agreements

Annual support contracts are designed to keep your terminal and PayClock software working seamlessly. For a single annual fee, your Support Agreement offers the following advantages:

- Unlimited toll-free telephone support (versus a per-call fee) and priority status for calls
- Unlimited access to the extensive library of web-based tips and FAQs
- Quick exchanges for damaged or broken terminal, thereby reducing downtime
- Extended parts and labor warranty helps you to save money on repairs needed after the regular product warranty has expired

To learn more about annual support contracts and to make a purchase, contact us at (800) 241-4990 or visit <http://www.lathem.com/support/support-plans.aspx>

Package Contents

Please verify that your package includes ALL of the following items. If your package is missing an item, please call our help desk at (800) 241-4990.



PC600 Series Terminal



AC Wall Adapter



User's Guide



Ethernet Cable



Mounting Screw Packet

3 screws to mount the terminal to the wall
3 anchors (use for masonry wall installation)
Securing clip (1 screw and anchor)

Recommended Installation Tools



Tape Measure



Pencil



Philips Head Screw Driver



Optional - Power Drill & Drill Bits

Appendix C - Access Relay Connections

When you are connecting to a door access device make sure you have the following skills:

- Understand basic wiring principles and techniques
- Can interpret wiring diagrams
- Have circuit wiring experience

Note: The wiring must be installed in accordance with national and local electrical codes.

Connecting the PC600 to a Door Strike

Unplug the relay screw terminal connector.

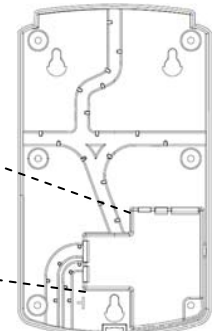
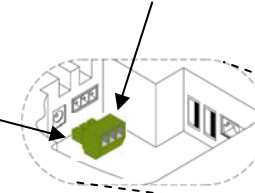
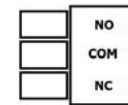

Connect the wires from the door access device to the screw terminals. Plug the terminal connector into the socket on the PC600. Only one (1) wire should be inserted into the terminal block positions NO and COM, all wire splices should be done externally. See the following diagrams for details.

Important! Relay contacts provide no power. The relay is a dry contact closure rated 2 amps at 24VDC or 120 VAC. Connecting a door strike that draws more than the rated amperage from the terminal will result in serious damage! It is recommended to use the RB8 Relay Booster Box for a door strike that requires more than 2 amps.

Wiring to P.A. System / Tone Generator

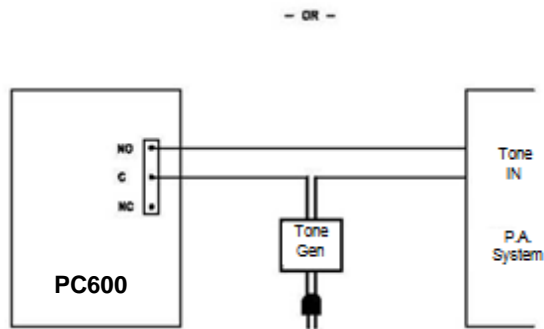
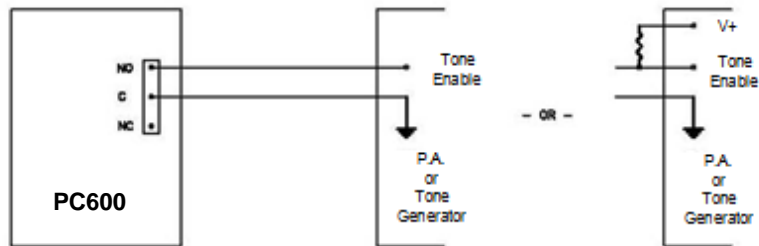

Important! Connecting the PC600 to a public address (PA) system requires the use of an external Tone Generator. Contact your PA supplier to acquire an appropriate Tone Generator for your system.

Install the PC600 Series Terminal

Step 1: Select a site to install your terminal that will be convenient to employees clocking in and out. When deciding where the terminal will be installed, keep in mind that an 115vAC power outlet should be within reach of the mounting location as well as a connection to the network (LAN).

Note: It is recommended to install and mount the terminal before installing the PayClock software. With the terminal powered up and connected to the network (LAN), the software will search for it on the network and automatically configure the terminal.

Step 2: After selecting the appropriate installation site, use masking tape to hold the included Mounting Template onto the wall. Drill holes using the template as a guide. Note: the bottom of the terminal should be about **45 inches** from the floor.

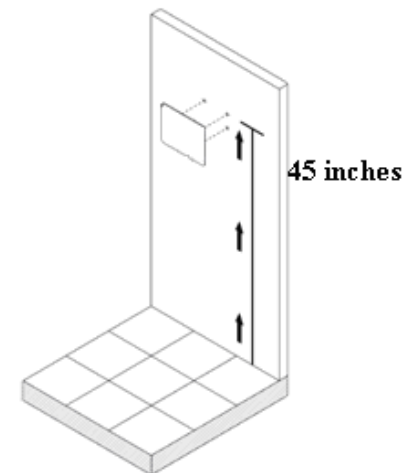

Remove the Template from the wall and install the included mounting screws. Install the three larger screws, leaving approximately 3/16 inch of the screws exposed. **Do not tighten all the way.** Retain the smaller screw for later.

Note: For sheetrock walls, drill a 3/16" diameter hole through each of the four screw locations; each approx 1-1/2" deep. Install the plastic "anchors" included in the mounting screw packet.

Step 3: Network Connection - Plug the RJ45 network cable into the Ethernet port and the Power Adapter plug into the Power Adapter port which is located in the compartment on the back of the terminal. See drawing below.

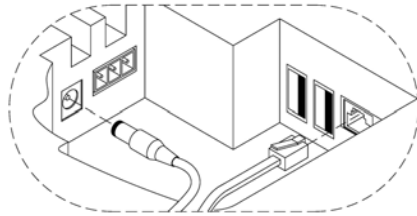

Insert the small "L"-shaped security bracket into the slot at the bottom-rear of the terminal, so that the tab with the hole points downward.

Hang the terminal on the wall, aligning the three keyholes on the rear of the enclosure with the three protruding screw heads, and then pressing downward on the terminal housing until it lowers onto the screws.

Screw the small Screw into the hole of the tab from the small "L"-shaped bracket at the bottom of the enclosure. This will fasten the terminal to the wall, and keep it from being easily removed.

When finished, plug the power adapter into an AC wall outlet.

Low Voltage 24V DC Bell Wiring with RB8

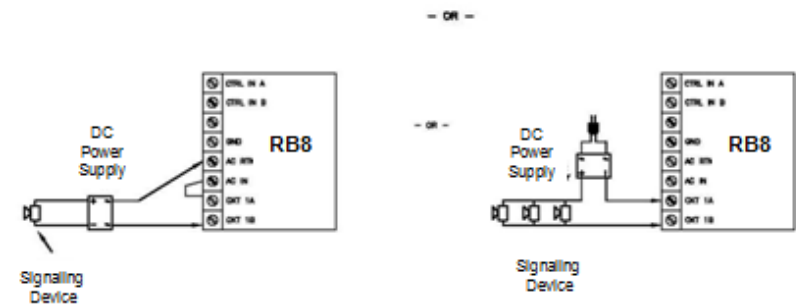
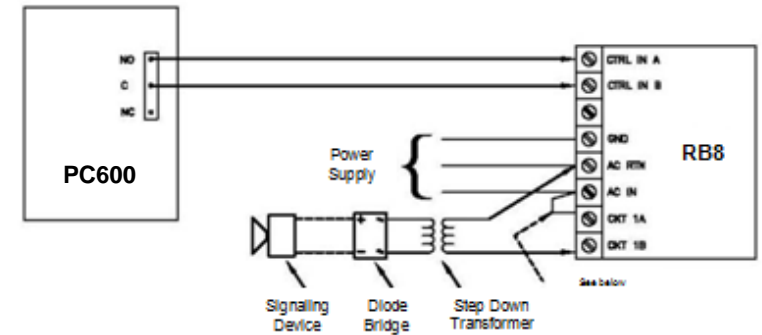

Low Voltage 24V DC Bell Wiring (Direct)

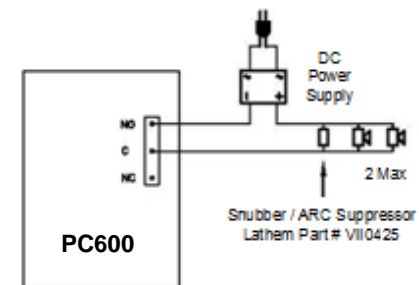

Low Voltage (24V) AC Bell Wiring (Direct)

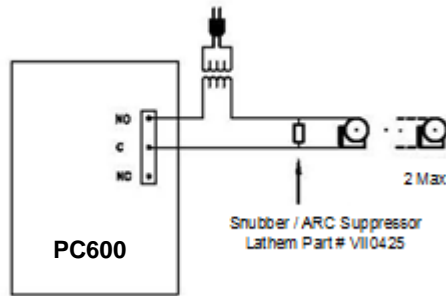

120V AC Bell Wiring with RB8

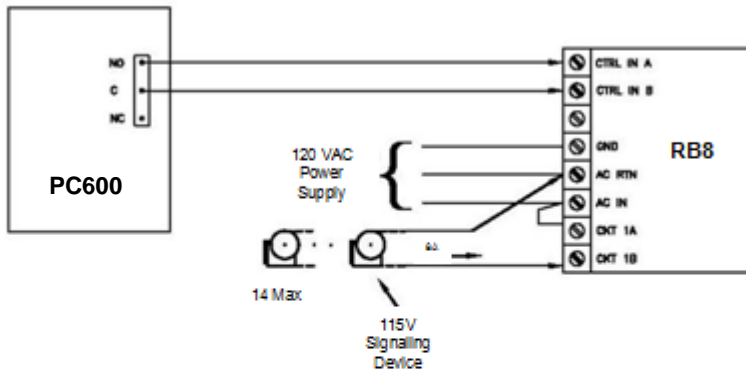

120V AC Bell Wiring (Direct)

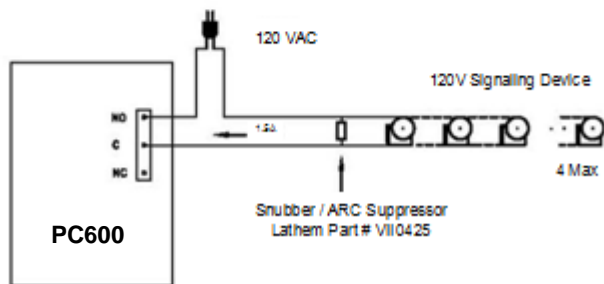

PayClock Online

The PC600 series terminal can be used with the PayClock desktop product or the PayClock Online product.

The PayClock desktop product is installed on a local pc and communicates with the terminal over the network.

The PayClock Online product is in the cloud and communicates with the terminal over the internet.

Adding a PC600 series terminal

Adding a PC600 series terminal to PayClock Online is a 2 step process. Add the terminal in PayClock Online first and then from the terminal connect to the hosted database.

Step 1 - Adding the PC600 series terminal

The PC600 series terminal **must** be added to PayClock Online first otherwise the connection will fail.

- Log into PayClock Online and select the Terminal Manager tab on the ribbon bar.
- Click the Add Terminals button. The Select Terminal Type window will open.
- Select PC600 from the drop down list and click OK.
- The terminal properties will display on the right.
- From the Connections tab enter the serial number of the terminal. Note: Enter the serial number **exactly** as it shows on the label on the terminal.
- Then enter a name for the terminal under Device Nickname.

- Select the **Enabled Hosted Mode** option. This will dim the Device IP Address field since it isn't used when operating the terminal in hosted mode.
- Click Save.

Step 2 - Connect the Terminal to PayClock Online

The PC600 series terminal must be added to PayClock Online before attempting this step. The terminal must be powered up and connected to the network with access to the internet.

- At the PC600 press the Admin button. Enter the administrator PIN and press Enter.
- From the Administrator Main Menu press **Network Setup**.
- Press **Define Host**. The Select Connection Method screen will display.
- Press **Hosted**.
- Press **Yes** to confirm using the Hosted option.
- Press **Connect**. The terminal will connect over the internet to PayClock Online.
- After connecting the data will be downloaded to the terminal and it will be ready for use.
- When complete a green icon  will show on the terminal's display identifying it is to the internet.
- The terminal will be operational and ready for use.

Changing settings at the Terminal

The default settings that can be changed by the administrator at the terminal or the PayClock Online software are:

- Time Zone: The time zone is set to Eastern Time.

Connect the wires from the signaling device to the screw terminals. Plug the terminal connector into the socket on the PC600. Only one (1) wire should be inserted into the terminal block positions NO and COM, all wire splices should be done externally. See the following diagrams for details.

Important! Relay contacts provide no power for signaling devices. The relay is a dry contact closure rated 2 amps at 24VDC or 120 VAC. Connecting a device or series of devices that draw more than the rated amperage from the terminal will result in serious damage! It is recommended to use the RB8 Relay Booster Box to control devices that require more than 2 amps.

Low Voltage 24V AC Bell Wiring with RB8

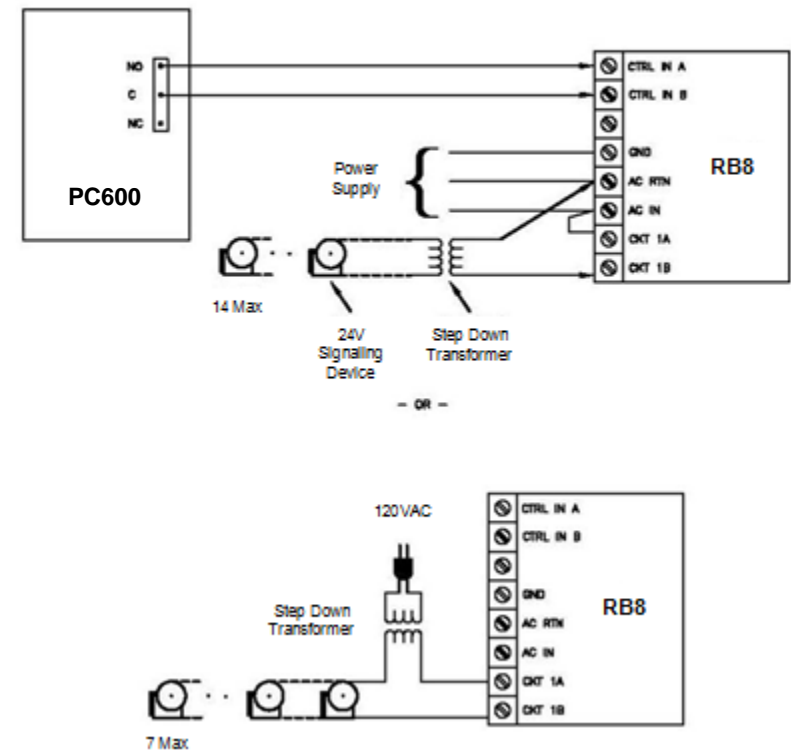

Appendix B - Bell Relay Connections

The PC600 has a built-in relay that can control bells or door access.

Relay Specifications

- Type: Dry Contact Closure
- Rating: 2 amps at 24VDC or 120VAC
- Contacts: NO-Normally Open, COM Common, NC Normally Closed

Bell Relay Connections

When you are connecting to a signaling device make sure you have the following skills:

- Understand basic wiring principles and techniques
- Can interpret wiring diagrams
- Have circuit wiring experience

Note: The wiring must be installed in accordance with national and local electrical codes.

To connect the signaling device

Unplug the relay screw terminal connector.

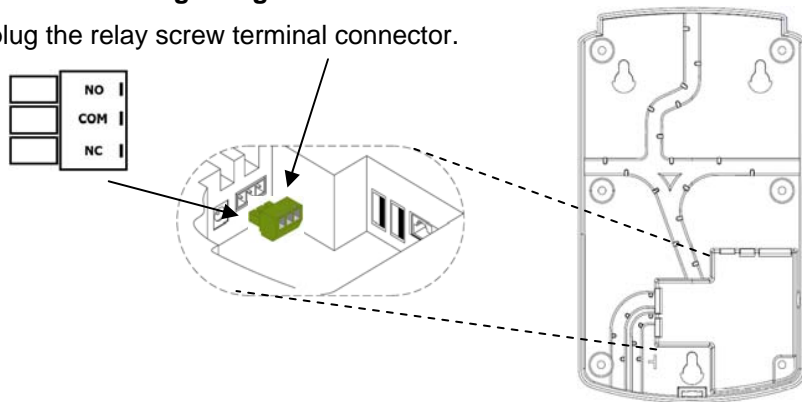

- Daylight Savings Time: Daylight savings is turned on.
- Time Format: The display will show the hours in a 12 hour (AM/PM) format.

The default settings that can only be changed through the PayClock Online software are:

- PIN Entry: PIN entry is turn on.
- Badge Entry: Badge entry is turned on.
- Allow Amounts: Amount entry is turned on.
- Maximum days to store registrations on terminal: Is set to 90 days.
- Send Date/Time on poll or update: Is turned on.
- Send worked hours and benefit time after poll: Is turned on.

How do I change the time zone?

- From the terminal touchpad press the Admin button. Enter the administrator password (PIN) and press the Enter button.
- The Administrator Main Menu screen will display.
- Press Date/Time Setup. The Date Setup screen will display.
- Press the Time Zone button. The Choose Time Zone screen will display.
- Using the up and down arrow keys select the desired time zone and click OK.
- When finished press the back ⏪ button until you have returned to the default screen.

How do I disable daylight savings?

- From the terminal touchpad press the Admin button. Enter the administrator password (PIN) and press the Enter button.
- The Administrator Main Menu screen will display.
- Press Date/Time Setup. The Date Setup screen will display.
- Under Daylight Save Time press Off.
- The screen will refresh with the newly selected option.

- When finished press the back ↵ button until you have returned to the default screen.

How do I change the displays time format?

- From the terminal touchpad press the Admin button. Enter the administrator password (PIN) and press the Enter button.
- The Administrator Main Menu screen will display.
- Press Date/Time Setup. The Date Setup screen will display.
- Under Time Display Format press either the 12HR or 24HR.
- The screen will refresh with the newly selected option.
- When finished press the back ↵ button until you have returned to the default screen.

Changing settings from PayClock

How do I change the time zone?

- Log into PayClock and select the Terminal Manager tab on the ribbon bar. The Terminal Manager window will open.
- Select the desired terminal from the list and click on the Settings tab.
- Under Time Zone select the desired time zone.
- Click Save.
- The terminal will update itself at the next update interval.

How do I disable daylight savings?

- Log into PayClock and select the Terminal Manager tab on the ribbon bar. The Terminal Manager window will open.
- Select the desired terminal from the list and click on the Settings tab.

- A green icon  will show on the terminal display identifying it is in live sync mode.
- The terminal will be operational and ready for use.

Note: All communications have to be initiated from the terminal when running as a WAN installation. For example you can't poll or update from the PayClock software. The terminal's Live Sync function will automatically send the punches to the database and also check to see if it needs to update itself.

- 2638 - PayClock Database Server

PC600 Series WAN Installation

- At the remote site install mount and connect the terminal to the network.
- With the terminal powered up and connected to the network press the Admin button and enter the administrator PIN (99999).
- The Administrator Main Menu will display. Press the Network Setup button.
- The Network Setup screen will display. If using a “static” IP address at the terminal select **DHCP = Off**. Set the terminal’s IP, Subnet Mask and Gateway address. If you are using DHCP, select **DHCP = On**. The IP, Subnet Mask and Gateway Address will automatically be set when the DHCP setting is On.
- Press the **Define Host** button. The Define Host screen will display.
- Press the **Host IP** button and enter the IP Address for the computer where the PayClock database server resides and press **OK**.

Note: Use the Server Summary or Connection Info print out for the PayClock database servers IP address.

- Under Live Sync press the **Enable** button. The Sync Now button will display.
- Press the **Sync Now** button. The screen will turn orange with “Downloading Latest Data From Host. Please Wait...”.
- When finished verify the connection.
 - Press the Admin button and enter the administrator PIN (99999).
 - The Administrator Main Menu will display press the Device Information button.
 - Verify that the correct Company Name shows.
 - Press the back ↵ button until you have returned to the default screen.

- Under Daylight Saving Time select Off.
- Click Save.
- The terminal will update itself at the next update interval.

How do I change the displays time format?

- Log into PayClock and select the Terminal Manager tab on the ribbon bar. The Terminal Manager window will open.
- Select the desired terminal from the list and click on the Settings tab.
- Under Time Format select the desired format.
- Click Save.
- The terminal will update itself at the next update interval.

How do I disable PIN entry for all employees?

The terminal will display “Not Authorized” if an employee tries to use a PIN.

- Log into PayClock and select the Terminal Manager tab on the ribbon bar. The Terminal Manager window will open.
- Select the desired terminal from the list and click on the Settings tab.
- Under General Settings uncheck the PIN Entry option.
- Click Save.
- The terminal will update itself at the next update interval.

How do I disable Badge entry for all employees?

The terminal will display “Not Authorized” if an employee presents a badge.

- Log into PayClock and select the Terminal Manager tab on the ribbon bar. The Terminal Manager window will open.
- Select the desired terminal from the list and click on the Settings tab.
- Under General Settings uncheck the Badge Entry option.
- Click Save.
- The terminal will update itself at the next update interval.

How do I disable amount entry for all employees?

The Enter Amounts button will not display on the terminals touchpad when Allow Amounts is disabled.

- Log into PayClock and select the Terminal Manager tab on the ribbon bar. The Terminal Manager window will open.
- Select the desired terminal from the list and click on the Settings tab.
- Under Feature Settings uncheck the Allow Amounts option.
- Click Save.
- The terminal will update itself at the next update interval.

How do I disable transfers for all employees?

The Transfers Depts. button will not display on the terminals touchpad when Allow Transfers is disabled

- Log into PayClock and select the Terminal Manager tab on the ribbon bar. The Terminal Manager window will open.
- Select the desired terminal from the list and click on the Settings tab.
- Under Feature Settings uncheck the Allow Transfers option.

Appendix A - PC600 Series WAN Installation

These instructions identify the steps to configure the terminal to communicate with the PayClock database server across the internet.

A print out of the “Server Summary” information is required for this set up. If the information was not printed during the PayClock software installation, follow these steps to access the information.

- At the computer where the PayClock database server resides, open the PayClock software.
- Click the PayClock orb on the upper left and from the menu, select **Support Assistant**.
- In the Support Assistant window, select **Connection Info**.
- Print the Connection_Info.txt file for use when configuring the terminal.

WAN Installation Requirements

- There must be a VPN tunnel connecting the local and remote sites. **Note:** A software based VPN is not supported. A hardware based VPN is required!
- A static IP address is **required** on the computer designated as the PayClock database server.
- A network administrator may be required to configure the network routers to route the ports used by the terminal and PayClock database server.

Important Port Information - The following ports are used for this type of installation.

- 7350 - PayClock Network Terminal Service
- 7351 - Auto Poll Service

<p>A blinking light shows in the small rectangular opening to the left of the illuminated oval on the front of the terminal. What does it mean?</p>	<p>This blinking light represents the connection to the network (LAN). If the light is not blinking there isn't a connection to the network (LAN).</p>
<p>What are the double green arrows  on the display representing?</p>	<p>PayClock Desktop - This represents that the terminal is running in "live sync" mode.</p> <p>PayClock Online - This represents that the terminal is connected to the internet.</p>
<p>How do I disable the idle screen on the terminal?</p>	<p>While the idle screen doesn't affect the operation of the terminal some users may wish to disable the feature. To disable the idle screen press the Admin button and enter 528436 then press Enter. Press OK to the confirmation message "Idle Screen Mode: Off". Note: to reactivate the idle screen simply enter the 528436 code again.</p>

- Click Save.
- The terminal will update itself at the next update interval.

PayClock Desktop

The PC600 series terminal can be used with the PayClock desktop product or the PayClock Online product.

The PayClock desktop product is installed on a local pc and communicates with the terminal over the network.

The PayClock Online product is in the cloud and communicates with the terminal over the internet.

Adding a PC600 series terminal

The Maintenance button group under the Terminal Manager tab is used to add, delete or search for terminals. You can add the terminal manually or have PayClock search and add the terminal.

How do I search from PayClock and add a PC600 series terminal?

- Open PayClock and select the Terminal Manager tab on the ribbon bar.
- Click the Discover button, the Terminal Discovery window will open.
- When the PC600 series is found an entry for the terminal will display in the list.
- Select the terminal in the list and click the Create button.
- The terminal properties will display on the right.
- From the Connection tab enter the name for the terminal under Device Nickname.

Troubleshooting the PC600 Series Terminal

If the PayClock software doesn't communicate with the terminal, try these suggestions:

General Troubleshooting

- Make sure that all connections are secure and the cable is in tact.
- Make sure that the network cable is securely connected to the Ethernet port on the terminal.
- Make sure that the terminal's power supply is securely connected to an electrical outlet.
- Make sure that the power supply is securely connected to the terminal and the unit is powered up.

PC600 Series Troubleshooting

If after going through each item above you are still not communicating with the terminal, have the network administrator or IT person make sure there aren't any issues with the network.

Issue	Resolution
The terminal shows "Not Found" when a badge is presented.	Make sure that the number that is printed on the badge matches what was entered in the Badge Number field in PayClock for the employee.

All settings, administrators, supervisors, employees and data will be cleared; you can not recover this information.

To enter into administrator mode at the terminal press the Admin button. The Enter PIN screen will display.

- Using the numeric key pad enter the administrator PIN number and press Enter.
- The Administrator Main Menu screen will display.
- Press Reset. The Clock Reset screen will display.
- Press the Reset Clock button.
- At the confirmation screen press Yes if you are sure you wish to reset and clear the terminal.
- The terminal will reboot and restart as if it were a new terminal that had never been used.

 **WARNING:** Use caution when selecting this menu item. This menu item will reset the entire terminal to the manufacturer default settings. All settings, administrators, supervisors, employees and data will be cleared; you can not recover this information.

- The Device IP Address and Server IP Address fields will automatically populate.
- Click the Test Connection button to verify communications with the terminal.

How do I add a terminal to PayClock from the PC600?

The PC600 series terminal has the ability send it's configuration over the network and add itself to the PayClock desktop software. The terminal must be powered up and connected to the network. **Note:** A static IP address is **required** at the computer designated as the PayClock database server.

- Make sure the PayClock desktop software is installed.
- Make sure you have made note of the IP address of the computer where the PayClock database server is installed. Follow these steps to access the information:
 - Open the PayClock software.
 - Click on the PayClock orb on the upper left.
 - From the menu, select **Support Assistant**.
 - In the Support Assistant window, select **Connection Info**.
 - Print the Connection_Info.txt file when it displays for configuring the terminal.
- At the terminal press the Admin button, enter the administrator PIN (default PIN is 99999) and press the Enter key.
- The Administrator Main Menu will display, press the Network Setup button.
- The Network Setup screen will display.
 - If using a "static" IP address at the terminal select **DHCP = Off**. Set the terminal's IP, Subnet Mask and Gateway address.

- If you are using DHCP select **DHCP = On**. The IP, Subnet Mask and Gateway Address will automatically be set when the DHCP setting is On.
- Press the **Define Host** button. The Select Connection Method screen will display.
- Press the **Local** button. The Define Host screen will display. **Note:** The Hosted button is only used for the PayClock Online product.
- Press the **Host IP** button and enter the IP Address for the computer where the PayClock database server resides and press **OK**.

Note: The PayClock database server's IP address is located on the Connection Info document that was printed earlier.

- Under Live Sync press the **Enable** button, the Sync Now button will display.
- Press the **Sync Now** button. The screen will turn orange with "Downloading Latest Data From Host. Please Wait...".
- When finished verify the connection.
 - Press the Admin button and enter the administrator PIN (99999).
 - The Administrator Main Menu will display. Press the Device Information button.
 - Verify that the correct Company Name shows.
 - Press the back ↵ button until you have returned to the default screen.
- When complete a green icon  will show on the terminal's display identifying it is in live sync mode.
- The terminal will be operational and ready for use.

- Use the left or right arrow keys to scroll through any errors.
- When finished press the center of the screen and then press the back ↵ button until you have returned to the default screen.

Relay Settings

This menu allows you to configure how the terminal uses the on-board relay.

To enter into administrator mode at the terminal press the Admin button. The Enter PIN screen will display.

- Using the numeric key pad enter the administrator PIN number and press Enter.
- The Administrator Main Menu screen will display.
- Press Relay Settings. The Relay Setup screen will display.
- Select the Mode.
 - Off - The relay is disabled.
 - Access - The relay will be used to activate a door strike allowing employees to enter the facility.
 - Signal - The relay will open/close to sound the signaling device.
- The Schedule button will display if Signal is selected. Press Schedule and enter the bell events. Up to 100 events can be programmed.
- Select the duration to for the relay. By default it is set at 5 seconds.
- Use the Test button to activate the on-board relay to test the connection.
- When finished press the back ↵ button until you have returned to the default screen.

See **Appendix D** for steps to add/edit/delete bell events.

Reset

Use caution when selecting this menu item. This menu item will reset the entire terminal to the manufacturer default settings.

To enter into administrator mode at the terminal press the Admin button. The Enter PIN screen will display.

- Using the numeric key pad enter the administrator PIN number and press Enter.
- The Administrator Main Menu screen will display.
- Press Date/Time Setup. The Date Setup screen will display.
- Under Daylight Save Time press either the On or Off.
- The screen will refresh with the newly selected option.
- When finished press the back ↵ button until you have returned to the default screen.

Date/Time Setup - Time Display Format

This menu allows you to manually configure how the hours will display on the terminal.

To enter into administrator mode at the terminal press the Admin button. The Enter PIN screen will display.

- Using the numeric key pad enter the administrator PIN number and press Enter.
- The Administrator Main Menu screen will display.
- Press Date/Time Setup. The Date Setup screen will display.
- Under Time Display Format press either the 12HR or 24HR.
- The screen will refresh with the newly selected option.
- When finished press the back ↵ button until you have returned to the default screen.

Error Log

This menu item displays any errors that the terminal may have experienced.

To enter into administrator mode at the terminal press the Admin button. The Enter PIN screen will display.

- Using the numeric key pad enter the administrator PIN number and press Enter.
- The Administrator Main Menu screen will display.
- Press Error Log. The Event Log Details screen will display.

Changing settings at the Terminal

How do I change the time source?

This setting allows you to select where the terminal will receive it's time from, the computer where the PayClock server is running or from the Internet.

- From the terminal touchpad press the Admin button. Enter the administrator password (PIN) and press the Enter button.
- The Administrator Main Menu screen will display.
- Press Network Setup. The Network Setup screen will display.
- Press Define Host. The Select Connection Method screen will display.
- Press Local. The Define Host screen will display.
- Under Select Time Source press either the Server (the computer where the PayClock server is running) or Internet.
- The screen will refresh with the newly selected option.
- When finished press the back ↵ button until you have returned to the default screen.

How do I change the time zone?

- From the terminal touchpad press the Admin button. Enter the administrator password (PIN) and press the Enter button.
- The Administrator Main Menu screen will display.
- Press Date/Time Setup. The Date Setup screen will display.
- Press the Time Zone button. The Choose Time Zone screen will display.
- Using the up and down arrow keys select the desired time zone and click OK.
- When finished press the back ↵ button until you have returned to the default screen.

How do I disable daylight savings?

- From the terminal touchpad press the Admin button. Enter the administrator password (PIN) and press the Enter button.
- The Administrator Main Menu screen will display.
- Press Date/Time Setup. The Date Setup screen will display.
- Under Daylight Save Time press Off.
- The screen will refresh with the newly selected option.
- When finished press the back ↵ button until you have returned to the default screen.

How do I change the displays time format?

- From the terminal touchpad press the Admin button. Enter the administrator password (PIN) and press the Enter button.
- The Administrator Main Menu screen will display.
- Press Date/Time Setup. The Date Setup screen will display.
- Under Time Display Format press either the 12HR or 24HR.
- The screen will refresh with the newly selected option.
- When finished press the back ↵ button until you have returned to the default screen.

How do I enable Live Sync from the terminal?

- From the PC600 series touchpad press the Admin button. Enter the administrator password (PIN) and press the Enter button.
- Press the Network Setup button. The Network Setup screen will display.
- Press Define Host. The Select Connection Method screen will display.
- Press Local. The Define Host screen will display.
- Under Live Sync, press Enable. The screen will refresh and the Sync Now button will appear.

- When finished press the back ↵ button until you have returned to the default screen.

Date/Time Setup - Time

This menu allows you to manually configure the time on the terminal.

To enter into administrator mode at the terminal press the Admin button. The Enter PIN screen will display.

- Using the numeric key pad enter the administrator PIN number and press Enter.
- The Administrator Main Menu screen will display.
- Press Date/Time Setup. The Date Setup screen will display.
- Press the Time button. The Time Setup screen will display.
- Using the up and down arrow keys set the hour, minute, AM/PM and click OK.
- When finished press the back ↵ button until you have returned to the default screen.

Date/Time Setup - Time Zone

This menu allows you to manually configure the time zone on the terminal.

To enter into administrator mode at the terminal press the Admin button. The Enter PIN screen will display.

- Using the numeric key pad enter the administrator PIN number and press Enter.
- The Administrator Main Menu screen will display.
- Press Date/Time Setup. The Date Setup screen will display.
- Press the Time Zone button. The Choose Time Zone screen will display.
- Using the up and down arrow keys select the desired time zone and click OK.
- When finished press the back ↵ button until you have returned to the default screen.

Date/Time Setup - Daylight Saving Time

This menu allows you to manually configure the DST on the terminal.

The terminal can operate in “Live Sync” (online mode). When operating with Live Sync enabled (online mode) communications with the pc are in real-time. For example when an employee punches at the terminal it is immediately added to the database and is available for viewing or editing.

To enter into administrator mode at the terminal press the Admin button. The Enter PIN screen will display.

- Using the numeric key pad enter the administrator PIN number and press Enter.
- The Administrator Main Menu screen will display.
- Press Network Setup. The Network Setup screen will display.
- Press Define Host. The Select Connection Method screen will display.
- Press Local. The Define Host screen will display.
- Under Live Sync press either the Enable or Disable.
- The screen will refresh with the newly selected option.
- You can click the Sync Now button and the terminal will connect to the PayClock software and make any needed updates automatically.
- When finished press the back ↵ button until you have returned to the default screen.

Date/Time Setup - Date

This menu allows you to manually configure the date, time, time zone, DST and how the hours will display on the terminal.

To enter into administrator mode at the terminal press the Admin button. The Enter PIN screen will display.

- Using the numeric key pad enter the administrator PIN number and press Enter.
- The Administrator Main Menu screen will display.
- Press Date/Time Setup. The Date Setup screen will display.
- Press the Date button. The Date Setup screen will display.
- Using the up and down arrow keys set the month, date, year and click OK.

- Press the Sync Now button. The screen will change color and display “Downloading latest data from host. Please wait...”.
- When complete a green icon  will show on the terminal display identifying it is in live sync mode.

Changing settings from PayClock

How do I change the time source?

This setting allows you to select where the terminal will receive it's time from, the computer where the PayClock server is running or from the Internet.

- Log into PayClock and select the Terminal Manager tab on the ribbon bar. The Terminal Manager window will open.
- Select the desired terminal from the list and click on the Settings tab.
- Under Time Source select the either the PayClock Server (the computer where the PayClock server is running) or NIST (Internet).
- Click Save.
- Update the terminal with these changes. **Note:** The terminal will update itself if Live Sync is enabled.

How do I change the time zone?

- Log into PayClock and select the Terminal Manager tab on the ribbon bar. The Terminal Manager window will open.
- Select the desired terminal from the list and click on the Settings tab.
- Under Time Zone select the desired time zone.
- Click Save.

- Update the terminal with these changes. **Note:** The terminal will update itself if Live Sync is enabled.

How do I disable daylight savings?

- Log into PayClock and select the Terminal Manager tab on the ribbon bar. The Terminal Manager window will open.
- Select the desired terminal from the list and click on the Settings tab.
- Under Daylight Saving Time select Off.
- Click Save.
- Update the terminal with these changes. **Note:** The terminal will update itself if Live Sync is enabled.

How do I change the displays time format?

- Log into PayClock and select the Terminal Manager tab on the ribbon bar. The Terminal Manager window will open.
- Select the desired terminal from the list and click on the Settings tab.
- Under Time Format select the desired format.
- Click Save.
- Update the terminal with these changes. **Note:** The terminal will update itself if Live Sync is enabled.

How do I enable Live Sync from the PayClock software?

- Log into PayClock and select the Terminal Manager tab on the ribbon bar. The Terminal Manager window will open.
- Select the desired terminal from the list and click on the Settings tab.

- Press Network Setup. The Network Setup screen will display.
- If you want to set the Host IP address IP press Define Host.
- The Select Connection Method screen will display. Press the Local button. Note: The Hosted button is only used for the PayClock Online product.
- Press the Host IP button.
- Using the numeric key pad enter the IP address of the computer where the PayClock database resides and press OK.

Network Setup - Time Source

This option is only available when the terminal is configured in Local mode for use with the PayClock Desktop product.

This option allows you to select where the terminal will receive it's time from; the computer where the PayClock server is running or from the Internet.

To enter into administrator mode at the terminal press the Admin button. The Enter PIN screen will display.

- Using the numeric key pad enter the administrator PIN number and press Enter.
- The Administrator Main Menu screen will display.
- Press Network Setup. The Network Setup screen will display.
- Press Define Host. The Select Connection Method screen will display.
- Press Local. The Define Host screen will display.
- Under Select Time Source press either the Server (the computer where the PayClock server is running) or Internet.
- The screen will refresh with the newly selected option.
- When finished press the back ⏪ button until you have returned to the default screen.

Network Setup - Live Sync

This option is only available when the terminal is configured in Local mode for use with the PayClock Desktop product.

To enter into administrator mode, at the terminal press the Admin button. The Enter PIN screen will display.

- Using the numeric key pad enter the administrator PIN number and press Enter.
- The Administrator Main Menu screen will display.
- Press Network Setup. The Network Setup screen will display.
- If you want to set the terminal's IP address as a "Static" IP turn off DHCP by pressing the OFF button. The screen will refresh and more buttons will become active.
- Press the IP Address button. The IP Address screen will display.
- Using the numeric key pad enter the IP address you want to assign to the terminal and press OK.
- Press the Subnet Mask button. The Subnet Mask screen will display.
- Using the numeric key pad enter the address you want to assign to the terminal and press OK.
- Press the Gateway button. The Default Gateway screen will display.
- Using the numeric key pad enter the address you want to assign to the terminal and press OK.
- When finished press the back ⏪ button until you have returned to the default screen.

Network Setup - Host Settings

This option is only available when the terminal is configured in Local mode for use with the PayClock Desktop product.

This menu allows you to manually configure the network communication settings between the terminal and PayClock software.

To enter into administrator mode at the terminal press the Admin button. The Enter PIN screen will display.

- Using the numeric key pad enter the administrator PIN number and press Enter.
- The Administrator Main Menu screen will display.

- Under Update Settings select the Live Sync Enabled option.
- At Update Interval Check select how often the terminal will check to see if any changes have been made. The default setting is 5 minutes. **Note:** You should take in consideration that during the terminals "live sync" function no punches will be accepted at the terminal.
- Click Save.
- Update the terminal with these changes.
- When complete a green icon  will show on the terminal display identifying it is in live sync mode.

How do I disable PIN entry for all employees?

The terminal will display "Not Authorized" if an employee tries to use a PIN.

- Log into PayClock and select the Terminal Manager tab on the ribbon bar. The Terminal Manager window will open.
- Select the desired terminal from the list and click on the Settings tab.
- Under General Settings uncheck the PIN Entry option.
- Click Save.
- Update the terminal with these changes. **Note:** The terminal will update itself if Live Sync is enabled.

How do I disable Badge entry for all employees?

The terminal will display "Not Authorized" if an employee presents a badge.

- Log into PayClock and select the Terminal Manager tab on the ribbon bar. The Terminal Manager window will open.
- Select the desired terminal from the list and click on the Settings tab.

- Under General Settings uncheck the Badge Entry option.
- Click Save.
- Update the terminal with these changes. **Note:** The terminal will update itself if Live Sync is enabled.

How do I disable amount entry for all employees?

The Enter Amounts button will not display on the terminals touchpad when Allow Amounts is disabled.

- Log into PayClock and select the Terminal Manager tab on the ribbon bar. The Terminal Manager window will open.
- Select the desired terminal from the list and click on the Settings tab.
- Under Feature Settings uncheck the Allow Amounts option.
- Click Save.
- Update the terminal with these changes. **Note:** The terminal will update itself if Live Sync is enabled.

How do I disable transfers for all employees?

The Transfers Depts. button will not display on the terminals touchpad when Allow Transfers is disabled

- Log into PayClock and select the Terminal Manager tab on the ribbon bar. The Terminal Manager window will open.
- Select the desired terminal from the list and click on the Settings tab.
- Under Feature Settings uncheck the Allow Transfers option.
- Click Save.
- Update the terminal with these changes. **Note:** The terminal will update itself if Live Sync is enabled.

Administrator Functions

The terminal has one administrator. The administrator function allows you to review the device information, set up the network communications, set the time / date, review an error log and reset the terminal to the factory defaults.

To enter into administrator mode at the terminal press the Admin button. The Enter PIN screen will display.

- Using the numeric key pad enter the administrator PIN number and press Enter.
- The Administrator Main Menu screen will display.

Device Information

This menu item displays information and also allows you to check for updates to the firmware. To check for updates:

To enter into administrator mode at the terminal press the Admin button. The Enter PIN screen will display.

- Using the numeric key pad enter the administrator PIN number and press Enter.
- The Administrator Main Menu screen will display.
- Press Device Information. The Device Information screen will display.
- Press the Check for Updates button. Please be patient this may take a few minutes.
- When finished press the center of the screen and then press the back ⏪ button until you have returned to the default screen.

Network Setup - Terminal Settings

This menu allows you to manually configure the network communication settings between the terminal and PayClock software.

Note: When using the PayClock Desktop product these settings are typically determined during the installation of the PayClock software and it isn't necessary to modify the settings.

- When finished press the  button to return to the default screen.

Settings - View/Assign Badge

This supervisor functions requires that the terminal be configured for Live Synch when using the PayClock Desktop product.

At the terminal press the Supervisor button. The Enter PIN screen will display.

- Using the numeric key pad enter the supervisors PIN number and press Enter or move the supervisors badge over the badge reader symbol below the illuminated oval target area on the front of the terminal.
- At the Select an Employee screen, press the button of the desired employee.
- Press Settings. The Change Settings screen will display.
- Press the View/Assign Badge button. The Badge Settings screen will display.

Change Badge

- Press the Change Badge button. Present the badge when prompted.
- At the confirmation screen select Yes to change the Badge.
- When finished press the  button to return to the default screen.

Disable Badge Entry

- Press the Disable Badge Entry option.
- You know Badge entry is disabled when there is a check in the box.
- When finished press the  button to return to the default screen.

Updating the Terminal

The Update button group is used to update a single terminal or all The PayClock software is used to manage the terminal(s). You can poll and update the terminal. This is done from the Terminal Manager tab within the PayClock software.

Note: A terminal running in “Live Sync” mode doesn’t have to be manually updated. Changes will be detected and the terminal will automatically update itself.

How do I update a terminal?

- Log into PayClock and select the Terminal Manager tab on the ribbon bar. The Terminal Manager window will open.
- Select the desired terminal from the list and click Update Selected Terminal or click Update All Terminals.
- Any changes will be sent to the selected terminal.

Polling the Terminal

The Poll button group is used to poll or retrieve data from a single terminal or all terminals. When a terminal is polled punch data will be added to the database allowing you to edit, export and report on the data.

Note: A terminal running in “Live Sync” mode doesn’t have to be polled. Punches are automatically added to the database.

How do I poll a terminal?

- Open PayClock and select the Terminal Manager tab on the ribbon bar. The Terminal Manager window will open.
- Select the desired terminal from the list and click Poll Selected Terminal or click Poll All Terminals.
- The punch data residing in the terminal will be added to the database and will be available in the timecard.

Activating Live Sync at the Terminal

A PC600 series terminal running in “Live Sync” mode doesn’t have to be polled or updated. Punches are automatically added to the database. Any changes will be detected and the terminal will automatically update itself.

Note: It is not recommended to activate Live Sync if the computer where the PayClock database server is running uses a wireless network connection. A PC600 series terminal running in Live Sync mode requires a constant connection to the computer running the database. A wireless network connection may not provide the computer a constant connection to the network which could be troublesome.

When the terminal’s “Live Sync” option is enabled its functionality increases. The following will be available in live sync mode:

- Real-time punches - Punches are added to the database automatically. No polling is needed.
- Automatic updating - The terminal will check the software to see if any changes have been made that requires an update. If there were changes the terminal will automatically update itself.
- Real-time totals - When an employee punches the worked hours will be calculated and displayed.
- Audio/Text Messages - Audio / text messages can be configured to play / display on the terminal.
- Supervisor functions - Allow a supervisor to do the following through the touchpad on the terminal; add employees, add or delete punches, set or change an employee’s PIN, set or change an employee’s badge number and override shift lock outs.

How do I enable Live Sync from the PayClock software?

- Log into PayClock and select the Terminal Manager tab on the ribbon bar. The Terminal Manager window will open.

Settings - Set/Change PIN

This supervisor functions requires that the terminal be configured for Live Synch when using the PayClock Desktop product.

At the terminal press the Supervisor button. The Enter PIN screen will display.

- Using the numeric key pad enter the supervisors PIN number and press Enter or move the supervisors badge over the badge reader symbol below the illuminated oval target area on the front of the terminal.
- At the Select an Employee screen, press the button of the desired employee.
- Press Settings. The Change Settings screen will display.
- Press the Set/Change PIN button. The PIN Settings screen will display.

Change PIN

- Press the Change PIN button and using the numeric key pad enter the new PIN for the selected employee and press Enter.
- At the confirmation screen select Yes to change the PIN.
- When finished press the  button to return to the default screen.

Delete PIN

- Press the Delete PIN button.
- At the confirmation screen select Yes to delete the PIN.
- When finished press the  button to return to the default screen.

Disable PIN Entry

- Press the Disable PIN Entry option.
- You know PIN entry is disabled when there is a check in the box.

Send Message

At the terminal press the Supervisor button. The Enter PIN screen will display.

- Using the numeric key pad enter the supervisors PIN number and press Enter or move the supervisors badge over the badge reader symbol below the illuminated oval target area on the front of the terminal.
- At the Select an Employee screen, press the button of the desired employee.
- Press Send Message. Select to send a sound message or a text message.
- Using the up and down arrows select the desired sound or text message.
- At the confirmation screen select Yes and OK. On the next punch the employee will receive the sound or text message.
- When finished press the  button to return to the default screen.

Override Lockout

At the terminal press the Supervisor button. The Enter PIN screen will display.

- Using the numeric key pad enter the supervisors PIN number and press Enter or move the supervisors badge over the badge reader symbol below the illuminated oval target area on the front of the terminal.
- At the Select an Employee screen, press the button of the desired employee.
- Press Override Lockout.
- At the confirmation screen select Yes to have the next punch for the employee ignore the shift lockout.
- When finished press the  button to return to the default screen.

- Select the desired terminal from the list and click on the Settings tab.
- Under Update Settings select the “Live Sync Enabled” option.
- Select the Update Interval Check setting.
- Click Save.
- Click Update Selected Terminal. Live sync will be enabled on the terminal.
- A green icon  will show on the terminal display identifying it is in Live Sync mode.

How do I enable Live Sync from the terminal?

- From the terminal touchpad press the Admin button and enter the administrator password.
- Press the Network Setup button. The Network Setup screen will display.
- Press the Define Host button. The Select Connection Method screen will display.
- Press the Local button. The Define Host screen will display. **Note:** The Hosted button is only used for the PayClock Online product.
- Under Live Sync press Enable. The screen will refresh and the Sync Now button will appear.
- Press the Sync Now button. The screen will change color and display “Downloading latest data from host. Please wait...”.
- When complete a green icon  will show on the terminal display identifying it is in live sync mode.

Using the PC600 Series Terminal

The terminal will be ready to be used after downloading the employees. The terminal allows employees, supervisors and administrators to perform certain functions such as punching In and Out.



To punch, move the badge over the badge reader symbol below the illuminated oval target area on the front of the terminal.

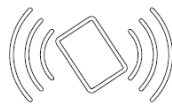

When the badge is in close proximity to the terminal; a confirmation beep will sound, a text message will appear, a custom audio message may be played, and the oval target area will turn either green or red indicating a good or bad transaction.

The terminal will display an error message if you scan a badge that has not yet been assigned to a specific employee in PayClock.

Notice: The terminal utilizes an internal antenna to read the employee badges. Make sure these badges are stored at least 6" away from the terminal when not in use to avoid accidental badge reads.

Adding Punches

This supervisor functions requires that the terminal be configured for Live Synch when using the PayClock Desktop product.

At the terminal press the Supervisor button. The Enter PIN screen will display.

- Using the numeric key pad enter the supervisors PIN number and press Enter or move the supervisors badge over the badge reader symbol below the illuminated oval target area on the front of the terminal.
- At the Select an Employee screen, press the button of the desired employee.
- Press View / Edit Punches. The Punches screen will display.
- Use the left or right arrows to select the desired date and press the +Punch button.
- Using the up and down arrows set the desired hour and minute and then click OK.
- At the confirmation screen select Yes to add the punch. The added punch will display on the screen and will be added to the timecard.
- When finished press the  button to return to the default screen.

Viewing Totals

At the terminal press the Supervisor button. The Enter PIN screen will display.

- Using the numeric key pad enter the supervisors PIN number and press Enter or move the supervisors badge over the badge reader symbol below the illuminated oval target area on the front of the terminal.
- At the Select an Employee screen press, the button of the desired employee.
- Press View Totals, the employee's grand totals for the pay period and any benefit time will display.
- When finished press the  button to return to the default screen.

- A confirmation beep will sound and the employee's grand totals for the pay period and any benefit time will display.

Supervisor Transactions

Supervisors have the ability at the terminal to view and edit employee punches, add new employees, send messages and override shift lockouts. To set up an employee as a supervisor, in the PayClock software check the Allow Supervisor Functions option for the desired employee.

Note: Some supervisor functions require that the terminal be configured for Live Synch when using the PayClock Desktop product.

To enter into supervisor mode at the terminal press the Supervisor button. The Enter PIN screen will display.

- Using the numeric key pad enter the supervisors PIN number and press Enter or move the supervisors badge over the badge reader symbol below the illuminated oval target area on the front of the terminal.
- The Select an Employee screen will display.

Viewing Punches

At the terminal press the Supervisor button. The Enter PIN screen will display.

- Using the numeric key pad enter the supervisors PIN number and press Enter or move the supervisors badge over the badge reader symbol below the illuminated oval target area on the front of the terminal.
- At the Select an Employee screen, press the button of the desired employee.
- Press View / Edit Punches. The Punches screen will display.
- Use the left, right, up or down arrows to scroll through the punch information.
- When finished press the  button to return to the default screen.

PC600 Series Terminal Idle Screen

The terminals display will change to an idle screen when there is no activity for 2 minutes. While in idle screen mode the day of the week, time and date will display in large easy to read characters. The terminal is fully functional while the screen is idle and the display will exit idle mode when a badge is presented or the screen is tapped or when the terminal is updated.

Idle Screen

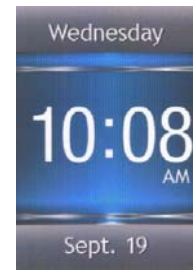

Home Screen

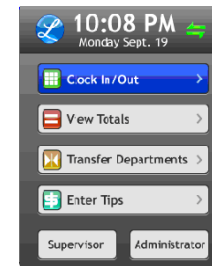

Employee Transactions using Badges

Employees can record transactions or view total information by presenting a badge.

Clocking IN/Out

- Move the badge over the badge reader symbol below the illuminated oval target area on the front of the terminal.
- When the badge is in close proximity to the terminal a confirmation beep will sound, a text message will appear, a custom audio message may be played, and the oval target area will turn either green or red indicating a good or bad transaction.

Department Transfers

- Press the **Transfer Depts.** button on the touch-pad of the terminal.
- Move the badge over the badge reader symbol below the illuminated oval target area on the front of the terminal.

- When the badge is in close proximity to the terminal a confirmation beep will sound, and the list of available departments will display.
- Press the button for the desired department. A confirmation screen will display showing the showing the department into which the employee transferred.

Amount Entries

- Press the **Enter Amounts** button on the touch-pad of the terminal.
- Move the badge over the badge reader symbol below the illuminated oval target area on the front of the terminal.
- When the badge is in close proximity to the terminal a confirmation beep will sound. The Enter Amt. screen will display.
- Using the numeric key pad enter the value for the amount and press Enter. A confirmation screen will display showing the showing the amount entered for the employee.

Viewing Totals

- Press the **View Totals** button on the touch-pad of the terminal.
- Move the badge over the badge reader symbol below the illuminated oval target area on the front of the terminal.
- When the badge is in close proximity to the terminal, a confirmation beep will sound, and the employee's grand totals for the pay period and any benefit time will display.

Employee Transactions using a PIN

Employees can record transactions or view total information by using the touch-panel on the terminal.

Clocking IN/Out

- Press the **Clock In/Out** button on the touch-pad of the terminal.

- The Enter PIN screen will display. Using the numeric key pad enter the employee's PIN number and press Enter.
- A confirmation beep will sound, a text message will appear, a custom audio message may be played, and the oval target area will turn either green or red indicating a good or bad transaction.

Department Transfers

- Press the **Transfer Depts.** button on the touch-pad of the terminal.
- The Enter PIN screen will display. Using the numeric key pad enter the employee's PIN number and press Enter.
- A confirmation beep will sound and the list of available departments will display.
- Press the button for the desired department. A confirmation screen will display showing the showing the department into which the employee transferred.

Amount Entries

- Press the **Enter Amounts** button on the touch-pad of the terminal.
- The Enter PIN screen will display. Using the numeric key pad enter the employee's PIN number and press Enter.
- A confirmation beep will sound. The Enter Amt. screen will display.
- Using the numeric key pad enter the value for the amount and press Enter.
- A confirmation screen will display showing the showing the amount entered for the employee.

Viewing Totals

- Press the **View Totals** button on the touch-pad of the terminal.
- The Enter PIN screen will display. Using the numeric key pad enter the employee's PIN number and press Enter.