

## 2000 - 4000 Series User's Guide



## Contents

Here’s all the information you need for setting and operating your new Lathem time recorder. Service information is also included in this manual, in case any problems ever arise.

Thank you for choosing a Lathem time recorder. Should you ever need assistance, please let us know.

Ordering Accessories .....	1
Setting the Time.....	2
Changing the Ribbon.....	9
Replacing the Type Section.....	10
Install / Replace Batteries in BATT .....	11
Changing the Motor.....	12
Warranty .....	13

## Warranty

### One-Year Limited Warranty

Lathem warrants the hardware products described in this guide against defects in material and workmanship for a period of **one year** from date of original purchase from Lathem or from an authorized Lathem reseller. The conditions of this warranty and the extent of the responsibility of Lathem Time Corporation (“Lathem”) under this warranty are listed below.

1. This warranty will become void when service performed by anyone other than an approved Lathem warranty service dealer results in damage to the product.
2. This warranty does not apply to any product which has been subject to abuse, neglect, or accident, or which has had the serial number altered or removed, or which has been connected, installed, adjusted, or repaired other than in accordance with instructions furnished by Lathem.
3. This warranty does not cover dealer labor cost for removing and reinstalling the machine for repair, or any expendable parts that are readily replaced due to normal use.
4. The sole responsibility of Lathem under this warranty shall be limited to repair of this product, or replacement thereof, at the sole discretion of Lathem.
5. If it becomes necessary to send the product or any defective part to Lathem or any authorized service dealer, the product must be shipped in its original carton or equivalent, fully insured with shipping charges prepaid. Lathem will not assume any responsibility for any loss or damage incurred in shipping.
6. **WARRANTY DISCLAIMER AND LIMITATION OF LIABILITY:** Except only the limited express warranty set forth above, the products are sold with no expressed or implied warranties of any kind, and the implied warranties of merchantability and fitness for a particular purpose are hereby expressly disclaimed. No warranties are given with respect to products purchased other than from Lathem or an authorized Lathem reseller and any such products are purchased “as is, with all faults.” In no event will Lathem be liable for any direct, special, or consequential damages arising out of or in connection with the delivery, use or inability to use, or performance of this product. In any event any limited remedy given herein shall be deemed to have failed of its essential purpose, Lathem’s maximum liability shall be to refund the purchase price upon return of the product.
7. Proof of date of purchase from Lathem or an authorized Lathem reseller is required for warranty service on this product.
8. This Warranty grants specific legal rights. Additional legal rights, which may vary by locale, may also apply.
9. Should any difficulties arise with the performance of this product during warranty, or with any Lathem authorized service centers, contact Lathem Time at the address below.

Lathem Time Inc  
 200 Selig Drive, SW, Atlanta, GA 30336  
 404-691-0405  
[www.lathem.com](http://www.lathem.com)

## Changing the Motor

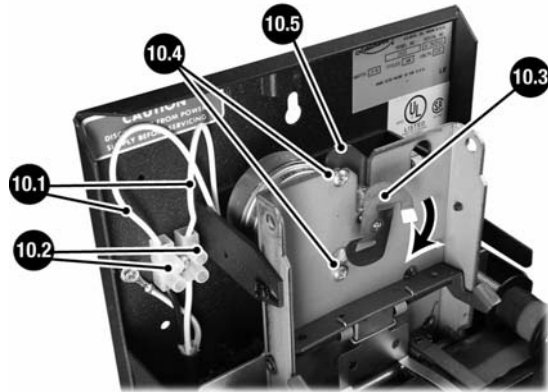

Figure 10

1. Unplug cord from wall outlet (except 2100BATT).
2. Remove type section from main frame (see “Replacing the Type Section”).
3. **Figure 10** shows a close-up of cam block terminal.
4. Disconnect **Motor Wire Leads** - **Figure 10, 10.1** by turning each **Screw** - **10.2** one-quarter of a turn counterclockwise.
5. Remove the **Motor Clutch** - **Figure 10, 10.3** from its shaft. The shaft has LEFT HAND threads - remove clutch by turning clockwise.
6. Hold **Motor Bracket** - **Figure 10, 10.4** and loosen **Motor Mounting Screws** - **Figure 10, 10.5**. Remove and retain screws and bracket from old motor.
7. Install motor clutch on new motor. Turn counterclockwise to tighten. **DO NOT OVERTIGHTEN OR BEND - YOU MAY DAMAGE INTERNAL MOTOR GEARS.**
8. Install new motor.
9. Install the new motor wire leads into the cam block terminal - **Figure 10, 10.1** by turning each **Screw** - **10.2** one-quarter of a turn clockwise.
10. Plug cord back in wall outlet, and reset the time.

## Ordering Accessories

Lathem time recorders fulfill a wide range of timekeeping requirements. For maximum results, only use Lathem accessories specifically designed to fit your time recorder.

To purchase the appropriate accessories for your time recorder, contact your local Lathem dealer or visit:

<http://shop.lathem.com>

Description	Part Number
Extra Pair of Keys	VSM0976
Replacement Ribbon, 2-Colors	7-2CN
Time Card Rack, 25 Capacity, 9" Card, Black, Plastic, Expanding	25-9EX
Time Card Rack, 12 Capacity, 9" Card, Black, Plastic, Expanding	12-9EX
Time Cards, Weekly (Box of 1,000)	1900L-C
Time Cards, Bi-Weekly (Box of 1,000)	L-31-1D
Time Cards, Semi-Monthly / Monthly (Box of 1,000)	1790
Time Cards, Job Costing (Box of 1,000)	350
Replacement Timing Motor, 110V/60Hz	K342

\* For additional information on Lathem's powerful employer software solutions or to download an evaluation copy of these applications visit us online at <http://www.lathem.com>.

## Setting the Time

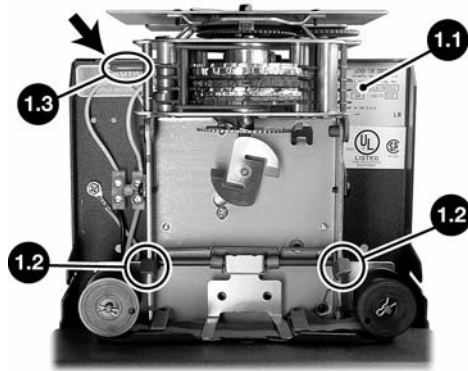

Figure 1

### Determine Your Model

Before proceeding, it is important to know the exact model of your clock so it can be set properly. The fourth digit in the model number indicates the print format.

Model	Print Hours	Print Units	Description
xxx1	1 - 12 , <u>1</u> - <u>12</u>	00 - 59	12 Hour & Minutes
xxx2	1 - 12 , <u>1</u> - <u>12</u>	.0 - .9	12 Hour & Tenths
xxx3	1 - 12 , <u>1</u> - <u>12</u>	.00 - .98	12 Hour & Hundredths
xxx4	00 - 23	00 - 59	24 Hour & Minutes
xxx5	00 - 23	.0 - .9	24 Hour & Tenths
xxx6	00 - 23	.00 - .98	24 Hour & Hundredths

*Example: Since the fourth digit in the model number 2104 is a "4", it will print with 00-59 minutes and 00-23 hours (see table above). The model number is located on the Label 1.1 positioned as shown in Figure 1.*

## Install / Replace Batteries in BATT



Figure 9

The 2000-BATT requires four "D" size batteries and should operate for six months before replacement. An internal beeper sounds momentarily each minute when the battery supply discharges below 4.5 volts. Replace batteries as follows when this occurs:

1. Pull and remove the front two rubber feet underneath the unit.
2. Loosen, 1 to 2 turns, the two phillips-head screws located 1.5 inches directly inside the rubber feet mounting holes.
3. Slide the bottom battery compartment outward (to front) and down, to get to the batteries. (See Figure 9.)
4. Replace the four "D" size batteries. Be sure the batteries are installed with proper polarity (+/-) as marked on battery holder.
5. Re-install the battery compartment on the bottom of the recorder, aligning the holes with the screws. Press the compartment firmly to the back (inward), tighten the two Phillips-head screws, and re-insert the two rubber feet.

## Replacing the Type Section

If your type section needs servicing, you can easily remove and replace it without sending the entire machine for service.

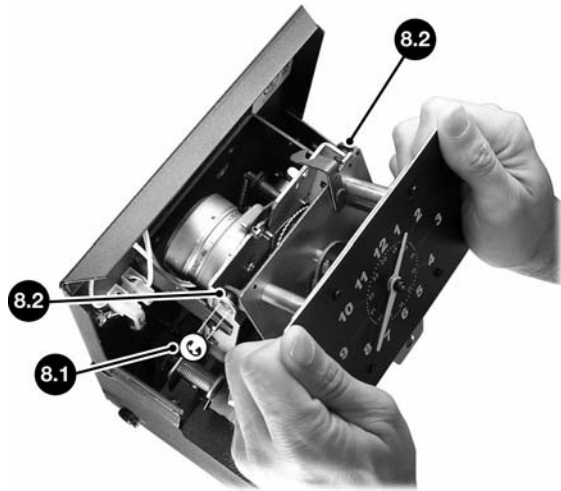

Figure 8

1. Remove the top cover.
2. Remove **Type Section Retaining Ring and Washer**- Figure 8, 8.1.
3. If the type section has digital time display, unplug connectors (not shown).
4. Lift type section slightly and move it to the right to release **Hinge Pins** - Figure 8, 8.2 from their sockets. The Type Section will lift out.

## Raise the Type Section

1. Unlock the case cover and pull it forward to remove it.
2. Note the position of the Release Latch and Face Setting Wheel used later in this process.
3. Wait until you hear the clock “click”.
4. Press either side of the **Type Section Headlock** - Figure 1, 1.2 and pull upward on the lower part of the Clock Face until the Type Section locks in the up position as shown in Figure 1. Note position of the Overthrow Lever and the Setting Wheel.
5. Press the red **Overthrow Lever** - Figure 1, 1.3 away from you until it clicks. This releases the wheels allowing them to turn.

## Set the Time on the Type Wheels

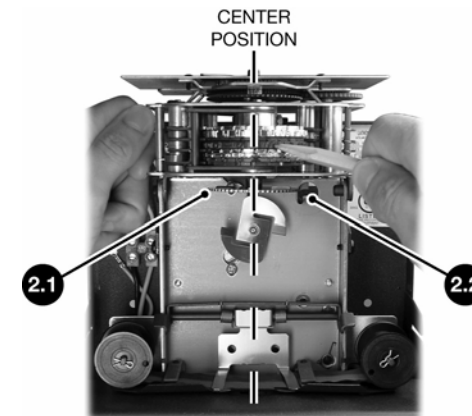

Figure 2

1. Locate the Center Line where all the wheels line up as shown in Figure 2.
2. Rotate the wheels using a pointed object. Rotate each wheel until the correct date and time are aligned at the Center Position, as shown in Figure 2. *Hint: Start at the top wheel and work down when setting.*

If your model prints Tenths, (models with the 4<sup>th</sup> digit of 2 or 5), go to the section “**Setting Decimal Wheel with Tenths**”.

If your model prints Hundredths or 00-23 hours, refer to the **Dial of Decimal Equivalents in Figure 3** (page 6) to determine the correct setting.

---

*Note: if your machine records in 1-12 hours, the PM hours are underlined. AM hours are not underlined. Set time to the proper hour of the day to avoid errors such as setting the day wheel to the next day at noon rather than midnight.*

---

3. Rotate the Minute Wheels to show the current minute.
4. Set the Hour Wheel to the current hour
5. Rotate the **Clock Face Setting Wheel - Figure 5.1 on page 8**, to set the hands to match the time set on the wheels.
6. Rotate the **Main Setting Wheel - Figure 2, 2.1** to advance both the Clock Face and Print Wheels together. Rotate until you pass the actual time by one minute (each “click” indicates one minute.)
7. Hold the corner of the Clock Face and release the **Release Latch - Figure 2, 2.2** by pushing it to the left. Slowly let the Type Section down and press it firmly into the Type Section Headlock.
8. Make a sample registration and verify the time and date or day is correct.
9. Replace and lock the case cover.

---

*Note: The month wheel and the date wheel must be reset manually at the beginning of each month.*

---

## Changing the Ribbon

Lathem time recorders have self-reversing ribbons. With normal use, a ribbon should last for many months or even years....and when the time comes, it is easy to change.

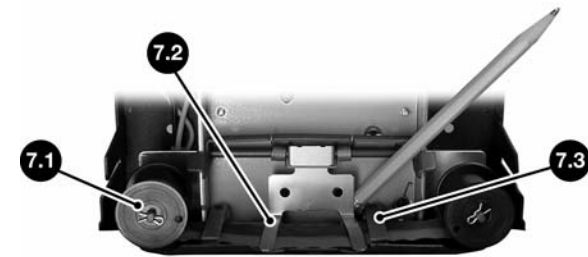

**Figure 7**

1. Remove the top cover and raise type section (see “Raise the type section” on page 4.)
2. Remove the **cotter pins - Figure 7, 7.1** that retain the ribbon spools and slide off old spools.
3. Lift **ribbon hold-down guide - Figure 7, 7.2** - use a pencil to support it in an up position.
4. Remove ribbon and replace with new Lathem ribbon. Make sure the ribbon feeds from bottom of the spools and runs **BETWEEN reversing fingers - Figure 7, 7.3**, the red side should be aligned with the date or day wheel(s).
5. Install cotter pins; remove pencil, and lower the type section into place.

## Set the Time on the Digital Clock Face



Figure 6

## Dial of Decimal Equivalents

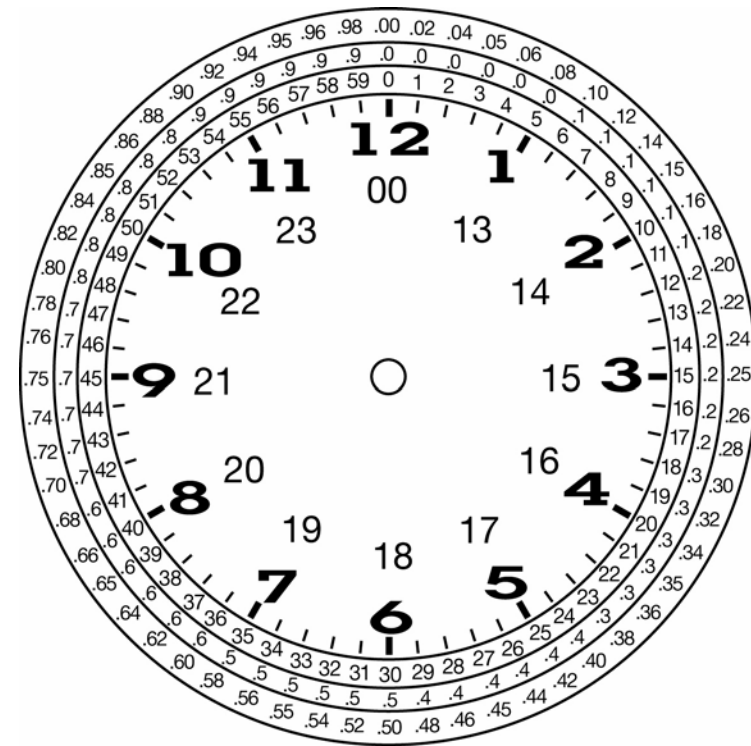

Figure 3

The dial in Figure 3 shows the tenths and hundredths setting for each minute. The inner circle represents regular minutes, the middle circle represents tenths, and the outer circle represents hundredths of a minutes.

For example:

45 minutes = .7 tenths = .75 hundredths

1. Make a sample registration on paper.
2. Use the Hour and Minute buttons to set the display to the time shown on the sample registration.
3. To synchronize the display with the type wheels, listen for the type wheels to click. At the click, press the minute button to advance to the next minute. Seconds are now synchronized. Always set the display to regular minutes. Refer to **Figure 3**, “dial of decimal equivalent” if wheels print in hundredths or tenths.

## Setting Decimal Wheel with Tenths

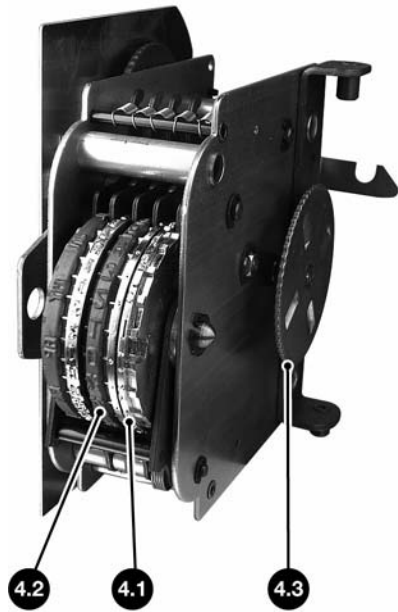

Figure 4

Use only for recorders printing in tenths (models with a 4<sup>th</sup> digit of "2" or "5")

1. Rotate Tenth's Wheel (0.9)- **Figure 4, 4.1** until it is set at "9" Rotate the Main Setting - **Figure 4, 4.3** until the Tenth's Wheel moves to a "0". (This is the zero minute.)
2. Set the Hour Wheel - **Figure 4, 4.2** to the current Hour.
3. Rotate the Clock Face Setting Wheel - **Figure 5, 5.1** to set the hands to match the time set on the wheels.

4. Rotate the Main Setting Wheel - **Figure 4, 4.3** to advance both the Clock Face and Print Wheels together. Rotate until you pass the actual time by one minute (each "click" indicates one minute.)

For example, at 10:05, rotate 5 times = 5 clicks = 5 minutes past ten o'clock.

5. Hold the corner of the Clock Face and release the Release Latch by pushing it to the left. Slowly let the Type Section down and press it firmly into the Type Section Headlock.
6. Make a sample registration and verify the time and date or day is correct.
7. Replace and lock the case cover

## Set the Time on the Analog Clock Face

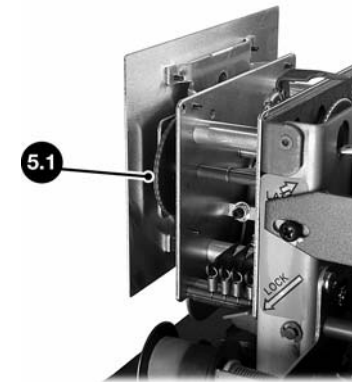

Figure 5

1. Make a sample registration on paper.
2. Rotate **Clock Face Setting Wheel 5.1** until the clock face displays the same time as shown on the sample registration.

**DO NOT TURN THE CLOCK HANDS EXCEPT BY USING THE SETTING WHEEL - Figure 5, 5.1.**