

PayClock[®] FaceIN

Time and Attendance System

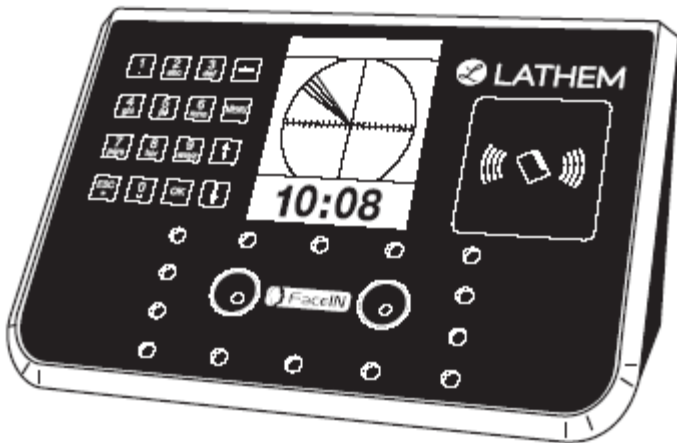

User's Guide



**THIS EQUIPMENT COMPLIES WITH FCC CLASS-B REQUIREMENTS
PURSUANT SUBPART J OF PART-15**

This device complies with Part 15 of the FCC Rules. Operation is subject to the following two conditions: (1) this device may not cause harmful interference, and (2) this device must accept any interference received, including interference that may cause undesired operation.

WARNING: Changes or modifications to this product not expressly approved by the party responsible for compliance could void the user's authority to operate this equipment.

NOTE: This equipment has been tested and found to comply with the limits for a Class B digital device, pursuant to Part 15 of the FCC Rules. These limits are designed to provide reasonable protection against harmful interference in a residential installation. This equipment generates, uses, and can radiate radio frequency energy and, if not installed and used in accordance with the instructions, may cause harmful interference to radio communications. However, there is no guarantee that interference will not occur in a particular installation. If this equipment does cause harmful interference to radio or television reception, which can be determined by turning the equipment off and on, the user is encouraged to try to correct the interference by one or more of the following measures:

- Reorient or relocate the receiving antenna.
- Increase the separation between the equipment and receiver.
- Connect the equipment into an outlet on a circuit different from that to which the receiver is connected.
- Consult the dealer or an experienced radio TV technician for help.

This Class B digital apparatus complies with Canadian ICES-003.

Cet appareil numérique de la classe B est conforme a la norme NMB-003 du Canada.



Lathem Time Corporation
200 Selig Drive, SW
Atlanta, Georgia USA 30336
(800) 241-4990
(404) 691-0400
www.lathem.com

Copyright © 2011 Lathem Time Corporation. All rights reserved.

Revised 08-17-2011

Document Number: USG0094D

CONTENTS

QUICK START STEPS V

WELCOME..... 1

PACKAGE CONTENTS 6

SYSTEM REQUIREMENTS 7

INSTALL THE FACEIN TERMINAL 8

FACEIN TERMINAL STARTUP..... 10

FACE ENROLLMENT GUIDE..... 13

ENROLLING EMPLOYEES AT THE TERMINAL 15

USING THE FACEIN TERMINAL 20

INSTALL THE PAYCLOCK SOFTWARE..... 24

SETTING UP A MULTI-USER SYSTEM..... 28

USING THE PAYCLOCK SOFTWARE 29

LOGGING INTO PAYCLOCK..... 31

SETTING UP PAYCLOCK..... 34

ADDITIONAL SOFTWARE SETUP..... 37

ADD THE FACEIN TERMINAL 39

ADD EMPLOYEES..... 40

EDITING TIMECARDS 45

GLOBAL SCHEDULING..... 63

REPORTS 64

SETTING UP YOUR TERMINAL..... 66

UPDATE THE TERMINAL..... 71

POLLING THE TERMINAL..... 72

AUTOMATIC POLLING..... 73

HARDWARE TROUBLESHOOTING 74

SOFTWARE TROUBLESHOOTING..... 76

APPENDIX A - EXPORTING PUNCHES TO A USB DRIVE 77

APPENDIX B - ADDING EMPLOYEES AT THE TERMINAL 79

APPENDIX C - CONNECTING THE FACEIN DIRECTLY TO THE COMPUTER'S NIC 84

APPENDIX D - ACCESS CONTROL..... 87

APPENDIX E - INTEGRATING PAYCLOCK WITH QUICKBOOKS... 90

APPENDIX F - FACEIN WAN INSTALLATION..... 92

APPENDIX G - PAYCLOCK CLIENT SOFTWARE WAN INSTALLATION..... 94

Copyright © 2011 Lathem Time Corporation. All rights reserved. Reproduction of this document in whole or in part is strictly prohibited. This document may contain typographical or copy errors. PayClock, Lathem, the Lathem logo, and all other Lathem product names mentioned in this document are registered trademarks of Lathem Time Corporation. All other products, brand names, or company names mentioned in this document are properties and trademarks or registered trademarks of their respective companies.

Quick Start Steps



Verify the contents of your system. (For more detailed information turn to page 6.)

Terminal Installation

1

Separate the mounting-plate from the FaceIN terminal by removing the Philips head screws. Retain the screws for later. (See page 8 for more details.)

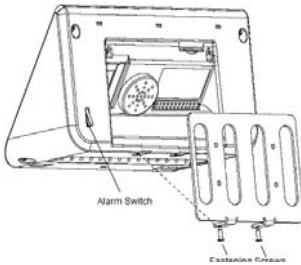

2

Install the mounting-plate to the wall using the supplied wall-mount screws. Note: For best visibility mount the terminal for the shortest employee, taller employees can bend down.



3

Plug the RJ45 network cable into the Ethernet port and the Power Adapter plug into the Power Adapter port which is located in the compartment on back of the terminal.



4

Align the FaceIN terminal with the pins on the mounting-plate and secure the two together with the 2 Philip head screws. Be careful not to pinch the AC cord.

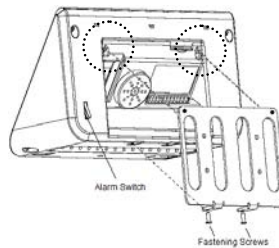

When finished, plug the Power Adapter into an AC wall outlet.

Terminal Startup

5



-Set up the network communications-

- Press the **MENU** key, the Functions Menu will open.
- Press **4**, the System Setting menu will open.
- From the System Setting menu, press **2** - Set Network.
- Enter the IP Address for the terminal and press **OK**.
- Enter the Mask Code and press **OK**.
- Enter the Gateway Address and press **OK**.
- The terminal will automatically restart. (For more detailed information turn to page 10.)

Note: You may have to contact your network administrator if you are unsure how to set up the network communications.

6

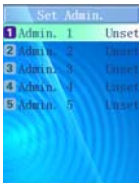

-Set up the first Administrator-

- Press the **MENU** key, the Functions Menu will open.
- Press **1**, the Set Admin menu will open.
- From the Set Admin menu, press **1** - Admin 1.
- Position your face and follow the prompts. (For more detailed information turn to page 11.)

Software Installation

7



-Verify System Requirements-

Verify your computer meets the Minimum System Requirements listed in this User Guide, turn to page 7.

8

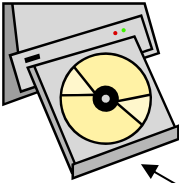

Install the **PayClock Software**. (For more detailed instructions turn to page 24.)

Important Notes

Make sure your screen saver is not showing before inserting the installation CD's.

Open and close the CD-ROM drawer if the CD is not recognized when inserted.

9



-Open PayClock-

Open the PayClock software by clicking on the PayClock Icon. The default password is **lathem**. (For more detailed instructions turn to page 31.)

10



-Configure the PayClock software-

Click Setup Now from the Get Started window to configure PayClock. (For more detailed instructions turn to page 34.)

11

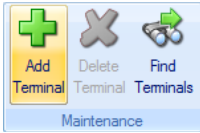

-Add the FaceIN terminal-

Click on the Terminal Manager tab and add the FaceIN terminal.

(For more detailed instructions turn to page 39).

12

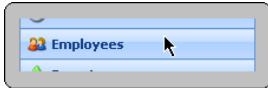

-Add the Employees-

Add employees using the **Employees** button under the **Setup** tab.

To add a new employee, click **New** and then enter the employee data.

(For more detailed instructions turn to page 40).

13

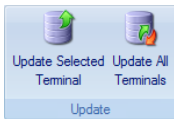

-Update the FaceIN terminal-

After adding the employees, update the FaceIN terminal.

(For more detailed instructions turn to page 71).

14

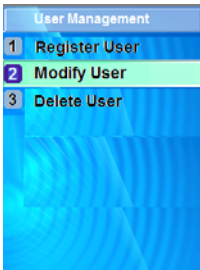

-Enroll Employee Faces-

After adding the employees in PayClock, register their faces at the terminal.

·Press the **MENU** key, and verify the administrator's face.

·After verification the Functions Menu will open.

·Press **2**, the User Management menu will open.

·Press **2**, the Modify User screen will open.

·Using the numeric keypad enter the desired employee's badge number and press **OK**.

·The employee's name will display, press **OK**.

·Select the verification method, have the employee position their face and follow the prompts. (See page 61 for details.)

·Press **ESC** at the "Permit Open Door?" Prompt.

·Press **OK** at the "Permit Attendance?" Prompt.

·Press **ESC**, **ESC** and **ESC** when finished.

(For more detailed instructions turn to page 15.)

Welcome

Purpose of this User's Guide

The purpose of this user's guide is not meant to be a complete manual for the product. It is a quick reference to get you started. Please refer to the PayClock Help for detailed product information, setup guidance, and operation information.

Product Overview

Reliability, functionality and ease of use are trademarks of the PayClock software and terminals. The terminal utilizes an “embedded facial recognition” system, meaning that employees will punch in and out by presenting their face in front of the terminal’s “Dual Camera System” .

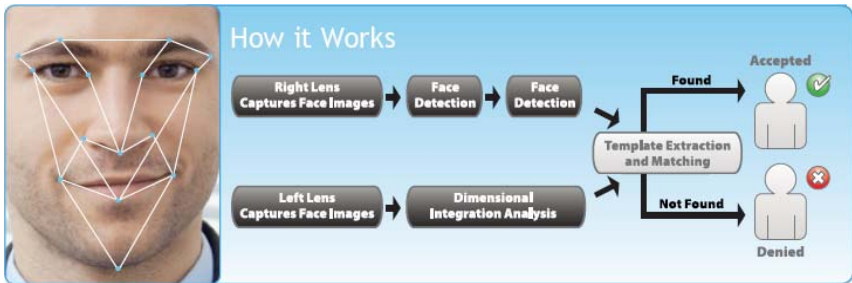

The FaceIN terminal connects to your network (LAN - PayClock software and FaceIN terminal have to be on the same subnet) for communications with the PayClock software. The PayClock software and FaceIN terminals are the ideal solution for businesses that want to track employee time and automate payroll.

The FaceIN terminal offers a large color LCD display that displays employee information along with an audio prompt. Upon a successful validation, the display will show the employee's name, time of punch and an audio prompt identifying a successful punch. When you're ready, you simply poll the terminal to add the punches to the database.

IMPORTANT

The FaceIN terminal operates independently from the computer where the PayClock software resides. The employee punches are retained in the terminal's memory and when you are ready simply poll the terminal.

Features and Specifications



- Embedded facial recognition system - Advanced DSP technology keeps the image processing and matching on the terminal.
- Accurate and fast identification - The industries leading “Dual Sensor” facial recognition technology.
- Reliable performance under different light environments - The terminal can work in different light conditions even in the dark. Over one year of market testing.
- Flexible I/O interfaces - Internet Protocol (TCP/IP) enables communications over the LAN. USB allows for employee data upload or punch download using a USB flash drive. The Ethernet Network Port is located on the back of the terminal and the USB Flash Drive Port is located on the bottom of the terminal.
- User friendly design - 3.5 inch color LCD screen for face positioning with voice prompt. No-touch authentication for the ultimate in hygiene.
- Easy-to-use PayClock software automatically calculates worked hours including overtime, tracks sick and vacation time and provides dozens of standard time and labor reports.

- Export hours directly from the PayClock software to most major payroll providers including ADP and Paychex.
- PayClock software offers seamless integration with the QuickBooks accounting products for a complete “punch-to-paycheck” solution.
- Comprehensive support agreements minimize technical difficulties.
- Numerous Accessory options further enhance the functionality of your PayClock and FaceIN system.

Note: The proximity badge reader and access control relay are not available on the FR650 model.

Upgrades

If you find that you need to accommodate more employees in your system or if you would like enhanced software capabilities, consider purchasing a software upgrade for your system. A number of accessories are offered to further enhance your PayClock system.

- Increased employee capacity
- Customized reporting options
- Customized export options
- Multi-user capabilities

Upgrading is as easy as visiting <http://shop.lathem.com> or open PayClock and click on the PayClock orb in the upper left corner and select **Upgrade PayClock**. Then select the options you would like to purchase and download your software upgrade. Options are instantly activated upon receipt of online payment.

Accessories

A number of accessories are offered to further enhance your PayClock system. Visit <http://shop.lathem.com> to purchase additional accessories like the ones listed below.

Getting Help

The purpose of this user's guide is not meant to be a complete manual for the product. It is a quick reference to get you started. Please refer to the PayClock Help for detailed product information, setup guidance, and operation information.

You can access the help desk and answers to your issues in a number of different ways. In addition to resources within the PayClock software, assistance may be accessed online, via email, via telephone, or through your dealer. Don't forget annual support contracts are also offered.

PayClock Help

The PayClock Help allows you to search through an index of help topics to locate the answer you need. To launch the Help, click the Help button on the ribbon bar.

Troubleshooting

For answers to Frequently Asked Questions, refer to the Troubleshooting sections of this User Guide on page 74 and 76.

Online and Email Support

Lathem.com provides access to numerous support resources that will allow you maximize your use of PayClock. Help may be accessed by visiting the following link:

<http://support.lathem.com>

On the Support page, you may also submit a question through our online knowledgebase and one of our technicians will respond to your inquiry within 24 hours. Email support is free to all registered users.

Telephone Support

The help desk is available between the hours of 8am and 7pm Monday through Friday. Please call **(800) 241-4990** to speak with our help desk. You will receive free technical support for the first 30

days after your initial call. After that period, you may purchase an Annual Support Agreement which will cover all calls for one year or you may pay a per-call fee.

Annual Support Agreements

Annual support contracts are designed to keep your terminal and PayClock software working seamlessly. For a single annual fee, your Support Agreement offers the following advantages:

- Unlimited toll-free telephone support (versus a per-call fee) and priority status for calls
- Unlimited access to the extensive library of web-based tips and FAQs
- Free software updates and version upgrades during the Support Period, giving you free access to the most current software features
- Quick exchanges for damaged or broken terminal, thereby reducing downtime
- Extended parts and labor warranty helps you to save money on repairs needed after the regular product warranty has expired

To learn more about annual support contracts and to make a purchase, contact us at (800) 241-4990 or visit <http://www.lathem.com/support/support-plans.aspx>

Package Contents

Please verify that your package includes ALL of the following items. If your package is missing an item, please call the help desk at 1-800-241-4990.

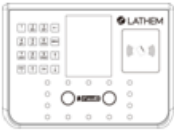

FacelN Terminal



Mounting-Plate



AC Wall Adapter



User's Guide



Software CD



Ethernet Cable



Wall Mount Template



Mounting Screw Packet

4 Screws to install the mounting-plate to the wall
 4 Anchors (use for masonry wall installation)
 2 Philips Head screws to install the FaceIN terminal to the mounting-plate

Recommended Installation Tools



Tape Measure



Pencil



Philips Head Screw Driver



Optional Power Drill & Drill Bits

System Requirements

You must verify that your system meets ALL of the minimum requirements listed below in order to run PayClock on your computer. Do not install the software if your system does not meet these minimum requirements!

Requirements:

- **Processor:** 1 GHz or higher
- **Operating System:** Microsoft Windows 32-Bit or 64-Bit
 - XP - SP2 or later
 - Vista
 - Windows 7
 - Server 2003 or 2008 (Standard or Enterprise Edition)
- **Memory:** 1 GB of RAM or higher
- **Hard Disk Drive:** Up to 450 MB free disk space; up to 1 GB if the .NET framework is not installed
- **Display:** 1024x768 or higher resolution
- **CD-ROM Drive:** Required
- **Internet:** 56 Kbps (broadband recommended for online features/services)
- **Printer:** Any printer compatible with Windows XP SP2 or later
- **Network Interface:** Network adaptor configured for TCP/IP connected to a switch on LAN network.
- **Additional Software:**
 - Microsoft .Net 3.5 SP1 (included in the installer)
 - Internet Explorer 7.0 or later

Install the FaceIN Terminal

Step 1: Select a site to install your FaceIN terminal that will be convenient to employees clocking in and out. When deciding where the terminal will be installed, keep in mind that an 115vAC power outlet should be within 6 feet of the mounting location as well as a connection to the network (LAN).

Note about Direct Sunlight - It is not recommended to have the terminal mounted in a location where it is exposed to direct sunlight. This could be troublesome during the registration process.

Step 2: After selecting the appropriate installation site, use the terminal to determine the appropriate height. Have the shortest employee stand in front of the terminal. Hold the terminal on the wall so that this employee can comfortably center their face in the LCD display window. Mark the height of the terminal on the wall.

Note: Taller employees can easily adjust their stance to center their face in the LCD display window.

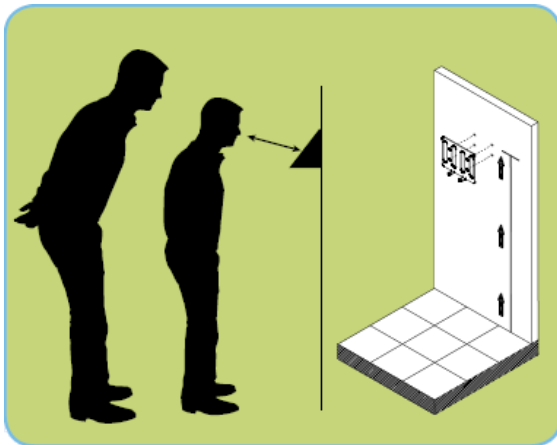

Install the mounting-plate to the wall using the supplied screws. For sheetrock walls, drill a 3/16" diameter hole through each of the four screw locations; each approx 1-1/2" deep. Install the plastic "anchors" included in the mounting screw packet.

Step 3: Plug the RJ45 network cable into the Ethernet port and the Power Adapter plug into the Power Adapter port which is located in the compartment on the back of the terminal.

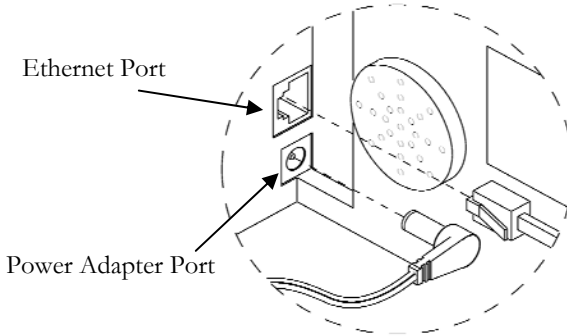

Step 4: Align the FaceIN terminal with the pins on the mounting-plate and secure the two together with the 2 Philips head screws. Be careful not to pinch the AC cord or network cable.

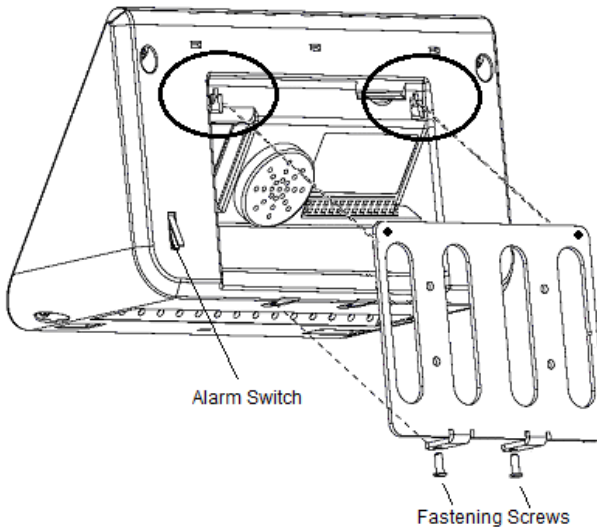

When finished, plug the power adapter into an AC wall outlet and proceed to the software installation.

FaceIN Terminal Startup

After completing the installation and power-up, the terminal will display the normal screen with the date, day of week and time.

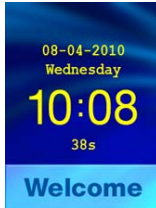

You are now ready to set up the network communications and define the initial administrator. **Note:** You must set up at least one administrator.

Set up the Network Communications

The FaceIN terminal must be configured to communicate with the PayClock software over the network. You may have to contact your network administrator if you are unsure how to set up the network communications.

- Press the **MENU** key, the Functions Menu will open.
- Press **4**, the System Setting menu will open.
- From the System Setting menu, press **2 - Set Network**.
- Enter the IP Address for the terminal and press **OK**.
- Enter the Mask Code and press **OK**.
- Enter the Gateway Address and press **OK**.
- Enter the Host computers IP address and press **OK**. (FR650 Only)
- The FaceIN terminal will restart automatically.

Note: You may have to enter leading zeros when entering the addresses. For example, the address **10.0.0.1** would be entered as **010.000.000.001** at the terminal.

Set up an Administrator

After setting up the network communications you will need to set up at least one administrator. **Note:** You can have up to 5 administrators.

- Press the **MENU** key, the Functions Menu will open.
- Press **1**, the Set Admin menu will open.
- From the Set Admin menu, press **1 - Admin 1**.
- The image collecting screen will display.
- Position the face in the middle of the two cameras with 9 to 25 inches between the face and the terminal.
- The image collecting screen will start the face recognition enrollment.
- Perform 2 small head circles to the right.
- Perform 2 small head circles to the left.
- Move the face closer to the terminal until the white dashed square appears.
- Move the face back until there is 9 to 25 inches between the face and the terminal.
- Turn the head fully to the right.
- Turn the head fully to the left.
- Raise the head up slightly.
- Lower the head down slightly.
- Move the face back from the terminal until there is 9 to 25 inches between the face and the terminal (if adjust position message is still displaying).
- Resume small head circles to the right (if adjust position message is still displaying).
- The progress bar at the bottom of the screen will display the process of the imaging.

When the face is successfully enrolled the terminal will display, “Add as User?”.

Ask yourself this question.

Will the administrator be using the door access function or punching In and Out on the terminal?

Yes - The administrator will be using the door access function or punching In and Out at the terminal.

- If the administrator will be punching In and Out or using the door access function at the terminal, press the **OK** key. The Input User No screen will display.
- Use the numeric keys to enter the user number and press **OK**. This should be the same as the PIN number you will enter into the PayClock software. The user number can be from 1 to 9999.
- Using the index/numeric keys enter a name. This should be the same as the first name you will enter into the PayClock software. After pressing the desired index/numeric key, use the ↑/↓ to move through the available letters. To change to caps, press the index/numeric key with the desired letter and press the **ESC** key. The letter group will change to caps. After entering the name, press the **OK** key.
- Select the verification method to use for this user.

No - The administrator will **not** be using the door access function or punching In and Out at the terminal.

- If the administrator will not be punching In and Out or using the door access function at the terminal, press the **ESC** key.
- The screen will display “Register Finished” and will return to the “Set Admin” menu. Press **ESC** and **ESC** again to return to the normal time/date screen.

Face Enrollment Guide

Follow these guidelines for trouble-free enrollments.

During the enrollment process the employee should keep their eyes centered on the screen at all times. Try to keep a solid green box around your face by following the steps below.

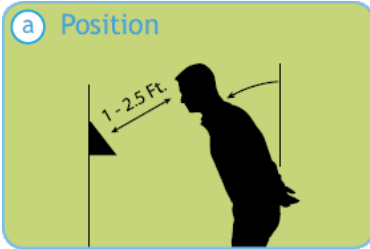

Position yourself and bend at the waist to bring your face 1 - 2.5 ft. from the screen on the terminal.

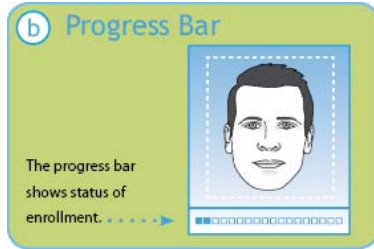

The line of squares at the bottom of the screen indicate how much data is needed to complete the enrollment.



The white dashed box is preparing to locate points. Identification images will only be taken when the green box appears around your face.

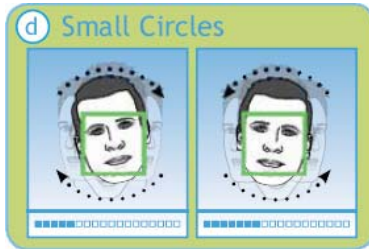

Slowly make an imaginary circle with your nose. Two small circles to the right and two to the left while **keeping your eyes centered on the screen.**

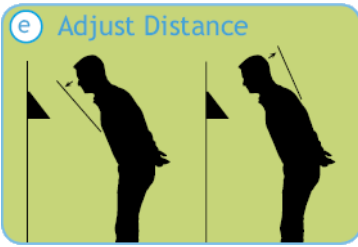

Slowly move your face closer until the white-dashed frame appears and then move away until the white-dashed frame appears.

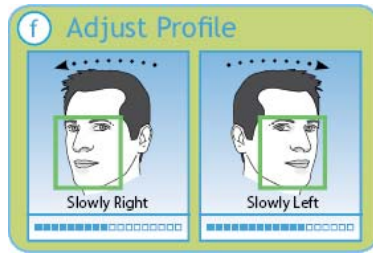

Slowly turn your head fully to the right, and then fully to the left, all the while keeping you eyes centered on the screen.

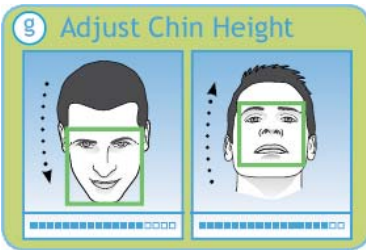

Tilt the head down slightly (chin lowered) while keeping your eyes on the screen, then tilt the head back slightly (chin upward).



If you wear glasses all of the time, or on occasion, you must initially enroll with your glasses on (sunglasses or dark tinted glasses are not allowed). Once the progress bar indicates enroll is 50% complete, REMOVE YOUR GLASSES and complete the enrollment without your glasses on.

Enrolling Employees at the Terminal

The FaceIN terminal utilizes an “embedded facial recognition” system, meaning that employees will punch in and out by presenting their face in front of the terminal’s “Dual Camera System”. The FaceIN terminal verifies the face image and records the punch. When you’re ready, you simply poll the terminal to add the punches to the database.

Before enrolling the employees update the FaceIN terminal first. From the Terminal Manager tab, click the Update button.

Enrollment Guidelines

- The FaceIN terminal is for use indoors; do not position the terminal in direct sunlight.
- Use normal facial expressions and avoid wearing sunglasses.
- If glasses or a hat is worn, please take the glasses and/or hat off halfway through the enrollment process for better face recognition.
- Bend into the camera, keeping the distance between the face and screen at 9 to 25 inches for best results.
- Keep the face centered between the 2 cameras.
- If the green lined frame displays when the employees face is successfully being detected.
- If the white dashed frame appears, the employees face can not be recognized, so please have the employee adjust their positioning.

The FaceIN terminal requires administrator verification in order to register employee faces.

- At the FaceIN terminal, press the **MENU** key, administrator verification is required.

- The administrator should present and position themselves for a facial scan. The Functions Menu will display upon a successful verification.
- Press **2** or select User Management and press **OK**, the User Management menu will display.
- Press **2** or select the Modify User menu and press **OK**.



- Use the numeric keys to enter the user number and press **OK**. The user number is the same as the badge number that was set up in the PayClock software.
- The employee's first name will display, press **OK** to continue.

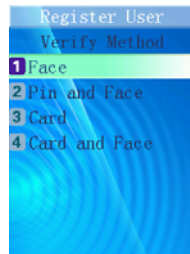

- With the employee standing at the ready, select the verification method to use for the employee.

Verify Method Recommendation: Typically for a normal employee you would select Face recognition, for a temporary employee select Card recognition, for higher security select either Pin and Face or Card and Face recognition.

When registering an employee's face take the following into consideration:

Eye Glasses - It is recommended for the employee to register with the eye glasses on for half the process, then remove the eye glasses and complete the registration.

Hair Style - If the employee has a hair style that has their hair covering or blocking their eyes, move the hair away from the eyes during the registration process.

Direct Sunlight - It is not recommended to have the terminal mounted in a location where it is exposed to direct sunlight. This could be troublesome during the registration process.

Face / Pin and Face Verification Method Selected

- Position the employee so the face is in the middle of the two cameras with 9 to 25 inches between the face and the terminal.
- The image collecting screen will display, start the face recognition enrollment.
- Perform 2 small head circles to the right.
- Perform 2 small head circles to the left.
- Move the face closer to the terminal until the white dashed square appears.
- Move the face back until there is 9 to 25 inches between their face and the terminal.
- Turn the head fully to the right.
- Turn the head fully to the left.
- Raise the head up slightly.
- Lower the head down slightly.
- Move the face back from the terminal until there is 9 to 25 inches between the face and the terminal (if adjust positioning message is still displaying).
- Resume small head circles to the right (if adjust positioning message is still displaying).

- The progress bar at the bottom of screen will display the process of the imaging.
- When the face is registered the terminal will display, “Permit Open Door?” press **ESC**. Note: Door access is not currently supported.
- When “Permit Attendance?” displays, press **OK**. Note: You must press OK; otherwise punches will not be recorded for polling.
- The screen will display “Finished” and will return to the “Input User No” screen. Continue with the next employee or press **ESC**, **ESC** and **ESC** again to return to the normal time/date screen.

Card Verification Method Selected (FR700 only)

- When “Please Swipe Card” displays, present the card at the terminal.
- When the card is registered the terminal will display, “Permit Open Door?” press **ESC**. Note: Door access is not currently supported.
- When “Permit Attendance?” displays, press **OK**. Note: You must press OK; otherwise punches will not be recorded for polling.
- The screen will display “Finished” and will return to the “Input User No” screen. Continue with the next employee or press **ESC**, **ESC** and **ESC** again to return to the normal time/date screen.

Card and Face Verification Method Selected (FR700 only)

- When “Please Swipe Card” displays, present the card at the terminal.
- Position the employee so the face is in the middle of the two cameras with 9 to 25 inches between the face and the terminal.

- The image collecting screen will display, start the face recognition enrollment.
- Perform 2 small head circles to the right.
- Perform 2 small head circles to the left.
- Move the face closer to the terminal until the white dashed square appears.
- Move the face back until there is 9 to 25 inches between their face and the terminal.
- Turn the head fully to the right.
- Turn the head fully to the left.
- Raise the head up slightly.
- Lower the head down slightly.
- Move the face back from the terminal until there is 9 to 25 inches between the face and the terminal (if adjust positioning message is still displaying).
- Resume small head circles to the right (if adjust positioning message is still displaying).
- The progress bar at the bottom of screen will display the process of the imaging.
- When the face is registered the terminal will display, “Permit Open Door?” press **ESC**. Note: Door access is not currently supported.
- When “Permit Attendance?” displays, press **OK**. Note: You must press OK; otherwise punches will not be recorded for polling.
- The screen will display “Finished” and will return to the “Input User No” screen. Continue with the next employee or press **ESC**, **ESC** and **ESC** again to return to the normal time/date screen.

Using the FaceIN Terminal

The FaceIN will be ready for use when the facial enrollment process is complete.



To punch, the employee will simply approach and look at the terminal, within seconds they are identified and punched In or Out.

Upon successful verification the terminal will play a confirmation sound and the screen will display the employee's first name and time of punch.

Clocking IN / Out

Employees can punch by presenting their face or a badge.

Clocking IN/Out - Face Verification

- The employee should step towards the terminal and stop when within 9 - 25 inches; the terminal will detect the employee and start the face recognition automatically.
- With the face detected, the screen will display a green radar screen rotating clockwise over the employee's image. A message will display at the bottom of the screen guiding the employee.

- When the employee's face is in the correct position, a green lined frame will display on the screen, and a green bar will scan the employee's image from top to bottom.
- During the face recognition process, the terminal will provide guidance for the employee, such as: "Please Get Closer", "Please Get Farther" or "Adjust Your Action".
- Upon successful verification the terminal will play a confirmation sound and the screen will display the employee's first name and time of the punch.

Clocking IN/Out - PIN & Face Verification

- Press the backspace key "←", at the Input User No. screen enter the employee's PIN and press OK.
- The employee should step towards the terminal and stop when within 9 - 25 inches; the terminal will detect the employee and start the face recognition automatically.
- With the face detected, the screen will display a green radar screen rotating clockwise over the employee's image. A message will display at the bottom of the screen guiding the employee.
- When the employee's face is in the correct position, a green lined frame will display on the screen, and a green bar will scan the employee's image from top to bottom.
- During the face recognition process, the terminal will provide guidance for the employee, such as: "Please Get Closer", "Please Get Farther" or "Adjust Your Action".
- Upon successful verification the terminal will play a confirmation sound and the screen will display the employee's first name and time of the punch.

Clocking IN/Out - Card & Face Verification (FR700 only)

- Move the badge over the badge reader symbol on the front of the FaceIN.



- When the badge is in close proximity to the FaceIN, a confirmation beep will sound.
- The employee should step towards the terminal and stop when within 9 - 25 inches; the terminal will detect the employee and start the face recognition automatically.
- With the face detected, the screen will display a green radar screen rotating clockwise over the employee's image. A message will display at the bottom of the screen guiding the employee.
- When the employee's face is in the correct position, a green lined frame will display on the screen, and a green bar will scan the employee's image from top to bottom.
- During the face recognition process, the terminal will provide guidance for the employee, such as: "Please Get Closer", "Please Get Farther" or "Adjust Your Action".
- Upon successful verification the terminal will play a confirmation sound and the screen will display the employee's first name and time of the punch.

Clocking IN/Out - Card Verification (FR700 only)

The Card Verification method only requires that the employee present their badge and then the terminal will take a snapshot of the person presenting the badge, no facial verification occurs.

- Move the badge over the badge reader symbol on the front of the FaceIN.



- When the badge is in close proximity to the FaceIN, a confirmation beep will sound and prompt the employee to take a photo.
- The employee should step towards the terminal; a snapshot will be taken of the person presenting the badge.
- The terminal will play a confirmation sound and the screen will display the employee's first name and time of the punch.

Install the PayClock Software

The PayClock install loads the client and server application as well as your database.

CAUTION: Before proceeding with your PayClock installation, verify that your PC meets ALL of the System Requirements listed on page 7!

Standard Install

Follow these instructions for these scenarios whether it is a new install or an upgrade:

- You want PayClock to only run on one computer.
- or-
- You want to install the PayClock Server in multi-user system (The multi-user license must be activated if you wish to access the PayClock software from different computers on your network. Additional license fees may apply. You will have to register your PayClock software first in order to activate the multi-user license.)

❑ Run the PayClock Setup Program

- Go to the computer where you want to install PayClock.
- Make sure your screen saver is not showing before inserting the PayClock CD.
- Insert the **PayClock CD** into your computer's CD-ROM drive. Note: If you are installing on Windows Vista or Windows 7 you may have to click Allow or Yes at the User Account Control confirmation window.
- The Setup program should run automatically. If not follow the steps below.
 - Click **Start | My Computer** or **Computer**.

- Double click on the drive that contains the PayClock installation CD.

❑ Follow the Setup Steps

- It may take the install a few minutes to start, please be patient.
- From the Install PayClock window click on **Next**.
- Read the License Agreement and select **I accept the terms of the license agreement** and **Next** to move forward.
- The Standard Install (Recommended) will be selected, click **Next** to continue.
- At the Ready to Install screen, click **Next**.
- At the Server Summary screen click the Print button, this data may be needed at a later time. Click **Next** to move forward.
- At the Installation Complete screen click **Finished**.

❑ Open PayClock

- After installing, you can run PayClock by clicking its icon. The default log in is Admin with the password 'lathem'.

❑ PayClock Product Registration

- From the Getting Started window, register PayClock via the Internet or phone. You must register within 30 days of installing the software. **Note:** You cannot activate the multi-user license until you register PayClock.

❑ Purchase Features

- Contact the help desk by calling 1-800-241-4990 or visit <http://shop.lathem.com> to purchase accessories and software modules.
- Options include employee capacity upgrades, multi-user, long-reach cables, additional badges, badge racks and more.

Client Installation in a Multi-User System

Follow these instructions when you want to run PayClock on more than one computer. These client instructions apply whether it is a new install or an upgrade. The PayClock Server must be installed before installing the Client software.

Note: The multi-user license must be activated if you wish to access the PayClock software from different computers on your network. Additional license fees may apply. In order to activate the multi-user license, you will have to register your PayClock software first.

❑ Run the PayClock Setup Program

- Go to the computer where you want to install the PayClock client.
- Make sure your screen saver is not showing before inserting the PayClock CD.
- Insert the **PayClock CD** into your computer's CD-ROM drive. Note: If you are installing on Windows Vista or Windows 7 you may have to click Allow or Yes at the User Account Control confirmation window.
- The Setup program should run automatically. If not, follow the steps below.
 - Click **Start | My Computer** or **Computer**.
 - Double click on the drive that contains the PayClock installation CD.

❑ Follow the Setup Steps

- It may take the install a few minutes to start, please be patient.
- From the Install PayClock window click on **Next**.

- Read the License Agreement and select **I accept the terms of the license agreement** and **Next** to move forward.
- Select the **Custom option** and click **Next** to continue.
- At the Install Client Only or Client & Server window, select **Client Only** and click **Next** to continue.
- At the Ready to Install screen, click **Next**.
- At the Installation Complete screen click **Finished**.

❑ Open PayClock

- After installing, you can run PayClock by clicking its icon. The default log in is Admin with the password '**lathem**'.

Setting up a Multi-User System

PayClock is by default a single user system. You must purchase and enable the multi-user feature in order to access PayClock from other computers on your network.

Note: You must register your PayClock software before enabling the Multi-User feature even if you have already paid for the feature. After registering PayClock, call the help desk for a feature un-lock code.

What is the difference between a Single User and Multi-User system?

With a single user system users cannot access the PayClock from different computers on the network. With a multi-user system other users can have the PayClock client installed on their computers and access PayClock across the network.

Enable the Multi-User Feature

- Open the PayClock software.
- Click on the PayClock orb in the upper left hand corner and select **Upgrade PayClock**.
- The Feature Wizard will open, click **Next**.
- At Number of Users select **Multi-user**.
- Click **Next** if you wish to demo the feature, click **Finish**. This will activate the feature for a 30 day trial.
- If you wish to purchase the feature select **Purchase the selected feature** and click **Next**.
- Enter your credit card information and click **Process Payment**.
- Your system will now be a multi-user system; you can install the PayClock client on other computers and access PayClock across the network.

See the PayClock Help for detailed information on setting up additional PayClock users.

Using the PayClock Software

PayClock utilizes a sleek user interface that allows you to get more out of the functions you use most. The interface provides centralized navigation to all parts and functions within the software. Navigation panes allow you to quickly manage payroll rules, employees, payroll data and reports. Simply click on a tab or button to open the pane and associated window. Use the “Quick Action” buttons under Payroll Process or Other Tasks to access routine operations.

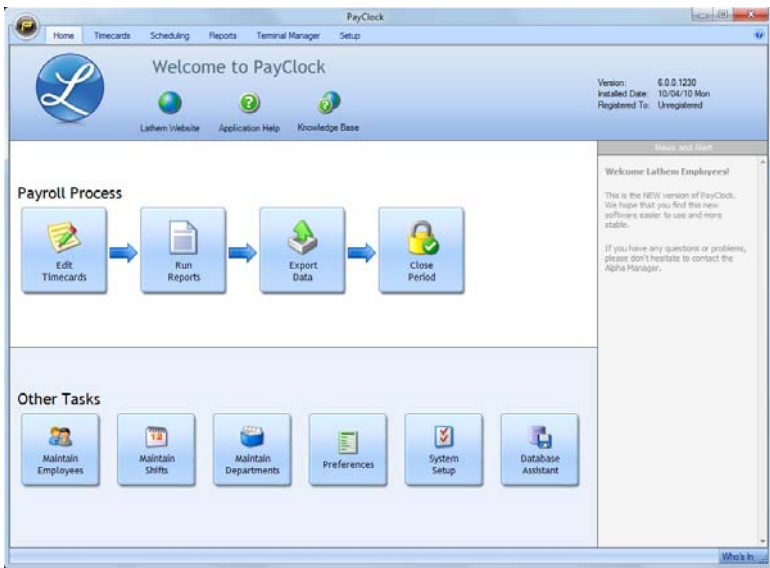

Using the Ribbon Bar

The PayClock **Ribbon Bar** has replaced the typical menus and toolbars. This new bar allows PayClock to present the functions you need on a set of organized tabs. The tabs are; Home, Timecards, Scheduling, Reports, Terminal Manager and Setup. This new ribbon bar makes using PayClock easier. Because of the way that the tabs are organized, you get to the functions quicker.

- **Home Tab:** The Home tab contains information on how to start using PayClock along with quick action buttons in a flow chart of the routine process of use.
- **Timecards Tab:** The Timecards tab contains functions for polling your terminal(s), editing employee timecards, globally editing a group of employees, exporting data for payroll and closing the pay period.
- **Scheduling Tab:** The Scheduling tab presents a summary or snapshot of the estimated labor coverage in hours and dollars in a calendar view. In addition the Scheduling tab is used to apply shifts to groups of employees, allowing shift assignments in mass rather than having to assign shifts to employees individually.
- **Reports Tab:** The Reports tab allows you to run reports on information that is stored in the PayClock database.
- **Terminal Manager Tab:** The Terminal Manager tab allows you to set up terminals and assign your employees to the terminals. You can also update and poll the terminals from this tab.
- **Setup Tab:** The Setup tab contains functions for configuring your company information, pay period rules, departments, employees, shifts, payroll exports, PayClock users and preferences.

The PayClock Orb

The **PayClock Orb**, located at the top left corner, allows quick access to a number of important tools. Click on the PayClock orb to access the following critical functions:

- Backup/Restore Data
- Upgrade PayClock
- Check for Updates
- Support Assistant
- Exit

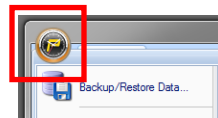

Logging into PayClock

PayClock is a single user system by default with one user account, Administrator. The Administrator account gives the user full access to PayClock.

Open the PayClock software by clicking on the  PayClock Icon located on your desktop.

Log In

To begin using PayClock, you must first Log In to the system at the **Log In** window. PayClock has one default user; the **Administrator**. The Administrator has full access to system, information, and functions.

NOTE

You may upgrade PayClock to a “Multi-User” system. Refer to page 28 of this User’s Guide for information on upgrading to multi-user.

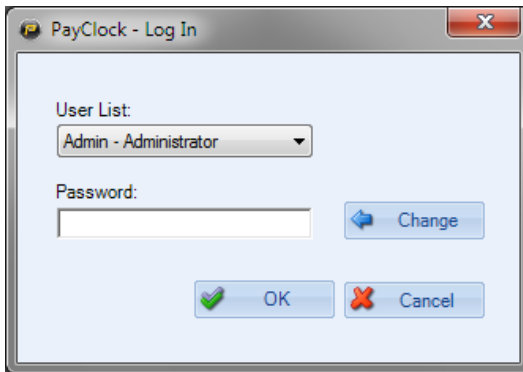

1. From the Log In window, choose **Administrator** from the **User List**.
2. Enter the default password: “**lathem**”.

3. Click **OK** and the software will open. A welcome tone will let you know that PayClock is ready for use.

Create and Change Your Password

You should create your own unique password to protect sensitive payroll data.

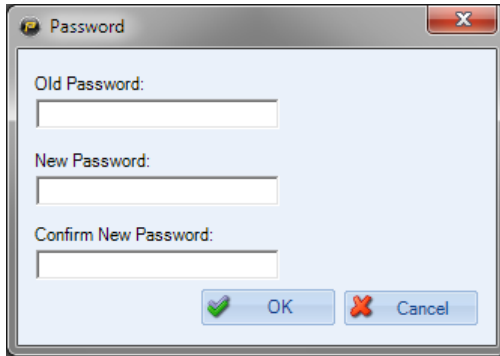

1. At the Log In screen, click the **Change** button.
2. Type in your **Old Password** (remember, the default is “lathem”).
3. Type in your **New Password** (the one you would like to create).
4. **Confirm** your new password by typing it in.
5. Click **OK** to finalize the change.

NOTE

Passwords **are** case sensitive and may be up to 11 characters

Register Your PayClock FaceIN System

You may register your system anytime within 30 days of installing the software. If after 30 days you haven't registered your system you will be required to do so before continuing to use the software.

There are three ways to register your software:

- Complete the **Registration Wizard** by clicking the Register Now button on the Get Started window that appears upon log-in. Fill in the requested information and submit. If you do not have an internet connection, select **Print** at the end of the wizard to print and fax your information to the help desk at **1-800-252-2208**.
- Call the help desk at **1-800-241-4990** and select option number 1 from the telephone menu to speak with a representative.
- Visit **<http://www.lathem.com/contact-us/register-your-product.aspx>** and follow the steps outlined.

Setting up PayClock

How does PayClock calculate time?

PayClock uses an open shift to define the start of the workday. An employee's open shift starts with his/her first punch of the day and continues until the day change or for 14 hours if working past the day change. The work day length is set to 14 hours by default.

Example 1:

- Jane Doe's first punch Monday morning was at 7:30 am.
- She didn't punch out to leave for the day until 10:00 pm. PayClock calculated her time as 14 hours and 30 minutes because she didn't work past the day change.

Example 2:

- Jane Doe's first punch on Tuesday was at 1:00 pm.
- Using the maximum work day length setting of 14 hours, PayClock defines the expected end of her open shift to be by 3:00 am on Wednesday.
- Jane's time will calculate and no missing registration exception will be generated if she punches out to complete her shift by 3:00 am on Wednesday.
- Jane's time will not calculate and a missing registration exception will be generated if she punches out to complete her shift after 3:00 am on Wednesday.

Minimum PayClock Set up

After completing the hardware and software installation, you should set up your basic company structure. This includes the pay period, overtime and rounding.

From the Getting Started window click the Setup Now button or click the Setup tab on the ribbon bar.

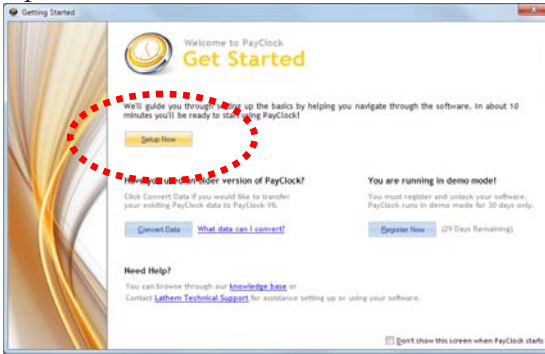

Use the buttons on the Setup tab to set up your basic company structure.

Pay Period Setup

- At the Setup tab, click the Pay Class button.
- Select the Standard pay class item from the List box on the left side of the window. The Standard pay class will open on the General tab.
- Select the Pay Period Type. The available options are Weekly, Bi-Weekly, Semi-Monthly, Monthly and Custom.
- Set when the pay period starts under the Current Pay Period date field.

Click the Help button is you need assistance setting up the pay period.

- Click Save to keep your changes.

Overtime Setup

- With the Standard pay class item still selected, click on the Overtime tab.
- To set up daily overtime, select the pay code and set the limit.

- To set up weekly overtime, select the pay code and set the limit.

Click the Help button is you need assistance setting up the overtime.

- Click Save to keep your changes.

Rounding Setup

- With the Standard pay class item still selected, click on the Advanced tab.
- Select the rounding option. **Note:** The “Not Selected” option will set the rounding to true time or minute to minute.

Click the Help button is you need assistance setting up the rounding.

- Click Save to keep your changes.

Shift Length Setup

The Maximum Work Day Length setting allows you to enter how long employees would normally work in one day. **Note:** Normally, you should leave this field at the default setting of 14 hours. If the setting too large you may see punches from different days linked together.

- With the Standard pay class item still selected, click on the Advanced tab.
- Enter the amount of time expected to be worked for a day in the Maximum Work Day Length field.. **Note:** It is recommended to leave the setting at the default 14 hours.

Click the Help button is you need assistance setting up the maximum work day length.

- Click Save to keep your changes.

Additional Software Setup

The Setup tab of the ribbon bar is used to configure the PayClock software for your company, pay period rules, departments, employees, shifts, payroll exports, PayClock users and preferences.

See the PayClock Help for detailed information on the Setup tab.

Company Button

At the Company button of the Setup tab you define your basic company information.

Pay Class Button

The Pay Class button of the Setup tab on the ribbon bar allows you set up and maintain your company's pay policies for handling payroll. You can configure the pay policies your company uses, such as your pay period, overtime, break and other advanced pay class features. The Pay Class set up consists of four tabs; General, Overtime, Break and Advanced.

Pay Codes Button

Pay Codes are accumulators or categories that collect either time or dollar amounts. You can change the pay rates or set the non-work hours to count toward overtime.

Departments Button

At the Departments button of the Setup tab you define the departments used by your company. Departments can be used to track time by groups of employees. Additionally you can use departments to filter lists of employees. Also, if your terminal supports employee transfers, you can create departments so employees can transfer from one department to another department. PayClock allows you to set up to 100 departments.

Breaks Button

At the Breaks button of the Setup tab you define the break and meal rules that will be applied to shifts. Breaks can be punched,

automatically deducted, or a combination of both. They can also be unpaid or paid. Breaks are applied to shifts. For example, you have a shift that starts at 7:30am and ends at 4:00pm with a 30 minute punched unpaid break that can be taken between 11:30am and 2:00pm. After defining the breaks assign them to shifts.

Shifts Button

At the Shifts button of the Setup tab you define the work day for employees. Shifts identify when an employee is expected to punch In or Out and how to calculate the punches. For each shift rule you can define the start and end of the shift as well as the break associated with the shift. For example, you have a shift that starts at 7:30am and ends at 4:00pm with a 30 minute punched break. After defining the shift rules you can then assign shifts to the employees.

Employees Button

The Employees button of the Setup tab on the ribbon bar allows you set up and maintain your employees in the software. You can enter their name, address, pay rate, emergency info, assign their benefit time, etc.

Exports Button

At the Exports button of the Setup tab you define how PayClock will export data to your payroll service. See Appendix E - Integrating PayClock with QuickBooks for details on working with QuickBooks.

Users Button

The Users button allows you to manage the user accounts for the PayClock software. You can add, edit and delete users and set or change the user passwords. When you click the Users button a list of the users will display.

Preferences Button

The Preferences button allows you to choose how dates and times display in the software; you also define certain software settings.

Add the FaceIN Terminal

After completing the set up of your company and payroll policies you will need to open the Terminal Manager tab and add the FaceIN terminal.



Adding the FaceIN Terminal

- Select the Terminal Manager tab on the ribbon bar and click the Add Terminal button. The Select Terminal Type window will open.
- Select FaceIN from the drop down list and click OK.
- The FaceIN terminal properties will display on the right.
- From the Connection tab enter the name for the terminal under Device Nickname.
- Enter the IP Address in the field, this is the address that was set up on the FaceIN terminal, click Save.
- Click the Test Connection button to verify communications with the FaceIN terminal.
- Select the Settings tab and click the Set button to send the time/date to the terminal.

Add Employees

The **Employees** button under the **Setup** tab is used to maintain the employees in the PayClock software. This will include adding, editing and terminating employees.

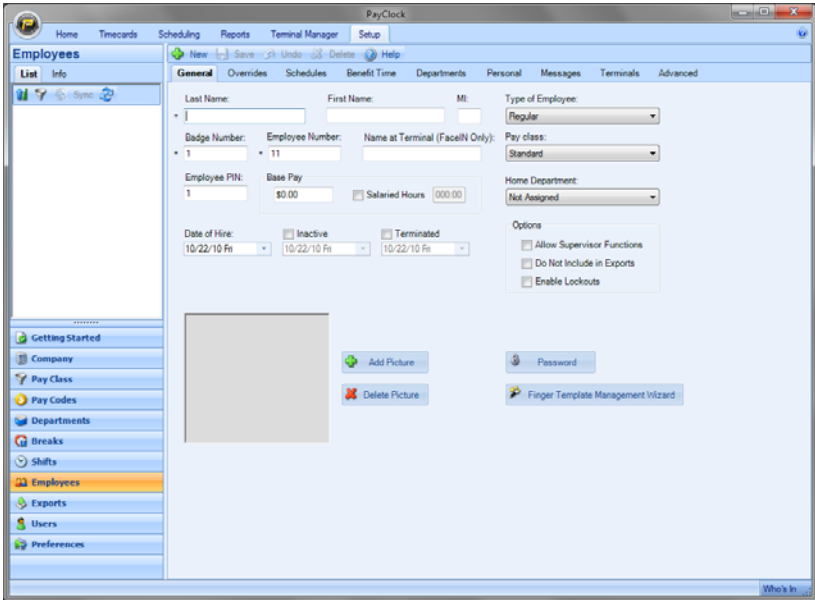

The **Employees** button has nine tabs - General, Overrides, Schedules, Benefit Time, Departments, Personal, Messages, Terminals and Advanced.

General Tab - Set up employee's name, badge and PIN.

Overrides Tab - Override global break settings for an employee.

Schedules Tab - Assign shifts to an employee.

Benefit Time Tab - Track benefit time for an employee.

Departments Tab - Assign optional departments to an employee.

Personal Tab - Set up employee addresses and contact information.

Messages Tab - Assign messages to display at the terminal.

Terminals Tab - Maintain employee assignments to terminals.

Advanced Tab - Override the maximum work day length and maximum hours out rule for an individual employee.

Add New Employees

General Tab

After adding the employees click on the Terminal Manager tab and update your terminal(s).

1. From the Ribbon Bar, click the Setup tab and click on the Employees button. The Employees window will display.
2. Click the New button, the next available blank employee template will display.
3. Type in the employee's last name, first name and middle initial.

NOTE: What you enter as the employees First Name will display at the FaceIN terminal. If you have more than one employee with the same first name, use the Name at Terminal field.

4. In the Badge Number field enter the badge number to use for punching in and out. Each badge contains a unique ten digit badge number on the back (see example below). **Note:** If you are not using badges, PayClock will automatically generate a badge number in the field, simply disregard the field. Badges are only used on the FR700 terminal.



5. If your company uses an Employee Number, enter it here. Usually, payroll services require an employee number for exports.
6. Use the Name at Terminal field if you have more than one employee with the same first name. This will allow you to differentiate the employee at the FaceIN terminal.
7. PayClock automatically fills in the Employee PIN but you can change it if you like. To change the PIN, enter the number in the Employee PIN field. **Note:** What is entered in the PIN field will be the cross reference in the FaceIN terminal. The PIN field allows for up to six numbers that can be from 1 thru 999999.
8. Enter the employee's hourly wage under Hourly Base Pay.
9. If the employee is salaried select the Salaried Hours option and enter how many hours the employee is expected to work during the pay period.
Note 1: Reports will use the hours you have entered in this field. Any punches will be ignored in reporting.
Note 2: Employees with the Salaried option selected can not be exported. The Do Not Include in Exports option will be checked and will be dimmed.
10. From the list under Type of Employee choose whether this person is Regular, Temporary, Seasonal or Contract.
11. At Pay Class select the pay class to use for the employee. This setting determines which pay period and overtime rules will be applied.
12. At Home Department select the employee's home department.
13. The Allow Supervisor Functions option is **not** supported with the FaceIN terminal.
14. At Do Not Include in Exports check this box if you do not want to include this employee in the file you export for payroll.

15. The Enable Lockouts option is **not** supported with the FaceIN terminal.
16. Enter the employee's hire date under Date of Hire.
17. Click Save to keep your changes.

The next section covers each topic briefly to give you an overview of the system. See the PayClock Help for detailed information on each topic.

Overrides Tab

You use the Overrides tab to define punched or automatically deducted breaks for individual employees on the open shift. Any defined breaks on this tab will override the global break set up on the Pay Class | Break tab.

Schedules Tab

The Schedules tab is used to apply shifts to individual employees. The shifts applied to the employee will make up the employees work schedule. You can define the employees work schedule in the calendar and assign shifts by date. The employee's schedule displays in a calendar view showing the shift details assigned to each date. A labor coverage chart is also available which verifies that there is enough labor coverage but not too much for a work day.

Employee	Monday	Tuesday	Wednesday	Thursday	Friday	Saturday	Sunday
OFF	OFF	OFF	OFF	OFF	OFF	OFF	OFF
7:00am-4:00pm	7:00am-4:00pm Hours: 8:00 Wages: \$80.00	7:00am-4:00pm Hours: 8:00 Wages: \$80.00	7:00am-4:00pm Hours: 8:00 Wages: \$80.00	7:00am-4:00pm Hours: 8:00 Wages: \$80.00	7:00am-4:00pm Hours: 8:00 Wages: \$80.00	7:00am-4:00pm Hours: 8:00 Wages: \$80.00	7:00am-4:00pm Hours: 8:00 Wages: \$80.00
12:00am-10:00am	12:00am-10:00am Hours: 8:00 Wages: \$80.00	12:00am-10:00am Hours: 8:00 Wages: \$80.00	12:00am-10:00am Hours: 8:00 Wages: \$80.00	12:00am-10:00am Hours: 8:00 Wages: \$80.00	12:00am-10:00am Hours: 8:00 Wages: \$80.00	12:00am-10:00am Hours: 8:00 Wages: \$80.00	12:00am-10:00am Hours: 8:00 Wages: \$80.00
12:00am-10:00am	12:00am-10:00am Hours: 8:00 Wages: \$80.00	12:00am-10:00am Hours: 8:00 Wages: \$80.00	12:00am-10:00am Hours: 8:00 Wages: \$80.00	12:00am-10:00am Hours: 8:00 Wages: \$80.00	12:00am-10:00am Hours: 8:00 Wages: \$80.00	12:00am-10:00am Hours: 8:00 Wages: \$80.00	12:00am-10:00am Hours: 8:00 Wages: \$80.00
OFF	OFF	OFF	OFF	OFF	OFF	OFF	OFF
7:00am-4:00pm	7:00am-4:00pm Hours: 8:00 Wages: \$80.00	7:00am-4:00pm Hours: 8:00 Wages: \$80.00	7:00am-4:00pm Hours: 8:00 Wages: \$80.00	7:00am-4:00pm Hours: 8:00 Wages: \$80.00	7:00am-4:00pm Hours: 8:00 Wages: \$80.00	7:00am-4:00pm Hours: 8:00 Wages: \$80.00	7:00am-4:00pm Hours: 8:00 Wages: \$80.00
12:00am-10:00am	12:00am-10:00am Hours: 8:00 Wages: \$80.00	12:00am-10:00am Hours: 8:00 Wages: \$80.00	12:00am-10:00am Hours: 8:00 Wages: \$80.00	12:00am-10:00am Hours: 8:00 Wages: \$80.00	12:00am-10:00am Hours: 8:00 Wages: \$80.00	12:00am-10:00am Hours: 8:00 Wages: \$80.00	12:00am-10:00am Hours: 8:00 Wages: \$80.00
OFF	OFF	OFF	OFF	OFF	OFF	OFF	OFF
7:00am-4:00pm	7:00am-4:00pm Hours: 8:00 Wages: \$80.00	7:00am-4:00pm Hours: 8:00 Wages: \$80.00	7:00am-4:00pm Hours: 8:00 Wages: \$80.00	7:00am-4:00pm Hours: 8:00 Wages: \$80.00	7:00am-4:00pm Hours: 8:00 Wages: \$80.00	7:00am-4:00pm Hours: 8:00 Wages: \$80.00	7:00am-4:00pm Hours: 8:00 Wages: \$80.00
12:00am-10:00am	12:00am-10:00am Hours: 8:00 Wages: \$80.00	12:00am-10:00am Hours: 8:00 Wages: \$80.00	12:00am-10:00am Hours: 8:00 Wages: \$80.00	12:00am-10:00am Hours: 8:00 Wages: \$80.00	12:00am-10:00am Hours: 8:00 Wages: \$80.00	12:00am-10:00am Hours: 8:00 Wages: \$80.00	12:00am-10:00am Hours: 8:00 Wages: \$80.00
OFF	OFF	OFF	OFF	OFF	OFF	OFF	OFF
7:00am-4:00pm	7:00am-4:00pm Hours: 8:00 Wages: \$80.00	7:00am-4:00pm Hours: 8:00 Wages: \$80.00	7:00am-4:00pm Hours: 8:00 Wages: \$80.00	7:00am-4:00pm Hours: 8:00 Wages: \$80.00	7:00am-4:00pm Hours: 8:00 Wages: \$80.00	7:00am-4:00pm Hours: 8:00 Wages: \$80.00	7:00am-4:00pm Hours: 8:00 Wages: \$80.00
12:00am-10:00am	12:00am-10:00am Hours: 8:00 Wages: \$80.00	12:00am-10:00am Hours: 8:00 Wages: \$80.00	12:00am-10:00am Hours: 8:00 Wages: \$80.00	12:00am-10:00am Hours: 8:00 Wages: \$80.00	12:00am-10:00am Hours: 8:00 Wages: \$80.00	12:00am-10:00am Hours: 8:00 Wages: \$80.00	12:00am-10:00am Hours: 8:00 Wages: \$80.00
OFF	OFF	OFF	OFF	OFF	OFF	OFF	OFF
7:00am-4:00pm	7:00am-4:00pm Hours: 8:00 Wages: \$80.00	7:00am-4:00pm Hours: 8:00 Wages: \$80.00	7:00am-4:00pm Hours: 8:00 Wages: \$80.00	7:00am-4:00pm Hours: 8:00 Wages: \$80.00	7:00am-4:00pm Hours: 8:00 Wages: \$80.00	7:00am-4:00pm Hours: 8:00 Wages: \$80.00	7:00am-4:00pm Hours: 8:00 Wages: \$80.00
12:00am-10:00am	12:00am-10:00am Hours: 8:00 Wages: \$80.00	12:00am-10:00am Hours: 8:00 Wages: \$80.00	12:00am-10:00am Hours: 8:00 Wages: \$80.00	12:00am-10:00am Hours: 8:00 Wages: \$80.00	12:00am-10:00am Hours: 8:00 Wages: \$80.00	12:00am-10:00am Hours: 8:00 Wages: \$80.00	12:00am-10:00am Hours: 8:00 Wages: \$80.00
OFF	OFF	OFF	OFF	OFF	OFF	OFF	OFF
7:00am-4:00pm	7:00am-4:00pm Hours: 8:00 Wages: \$80.00	7:00am-4:00pm Hours: 8:00 Wages: \$80.00	7:00am-4:00pm Hours: 8:00 Wages: \$80.00	7:00am-4:00pm Hours: 8:00 Wages: \$80.00	7:00am-4:00pm Hours: 8:00 Wages: \$80.00	7:00am-4:00pm Hours: 8:00 Wages: \$80.00	7:00am-4:00pm Hours: 8:00 Wages: \$80.00
12:00am-10:00am	12:00am-10:00am Hours: 8:00 Wages: \$80.00	12:00am-10:00am Hours: 8:00 Wages: \$80.00	12:00am-10:00am Hours: 8:00 Wages: \$80.00	12:00am-10:00am Hours: 8:00 Wages: \$80.00	12:00am-10:00am Hours: 8:00 Wages: \$80.00	12:00am-10:00am Hours: 8:00 Wages: \$80.00	12:00am-10:00am Hours: 8:00 Wages: \$80.00

Benefit Time Tab

You use the Benefit Time tab to track an employee's benefits, such as how much sick or vacation time they have or have taken. You can track up to 5 pay codes. The software keeps track of how much time the employee has taken and how much time the employee has left.

Departments Tab

The Departments tab is used to assign employees to certain departments and also modify the pay rate when working in the department. When an employee transfers to one of these assigned departments their pay rate will reflect what was defined for that particular department. **Note:** Department transfers are not supported at the FaceIN terminal.

Personal Tab

You use the Personal tab to keep track of certain employee information, such as their address, phone number, custom field information and who to contact in an emergency.

Messages Tab

The FaceIN terminal does not support employee messages.

Terminals Tab

The Terminals tab is used to assign or remove an employee's assignment to the terminal(s) you have setup in your PayClock system.

Advanced Tab

The Advanced tab is used to override the maximum work day length and maximum hours out rule for an employee. Either of these settings will override the Maximum Work Day or Maximum Hours Out to Start a New Shift setting on the Advanced tab of the Pay Class.

Editing Timecards

The Timecards tab is used to manage employee punch data. You can view and edit employee punches as well as non-work time such as vacation time or dollar amounts such as tips. You can view employee data for open or closed pay periods. When you click on the Timecards tab you will see 4 areas, the Timecard Ribbon Bar, the Employee List, the Employee Timecard and the Timecard Timeline.

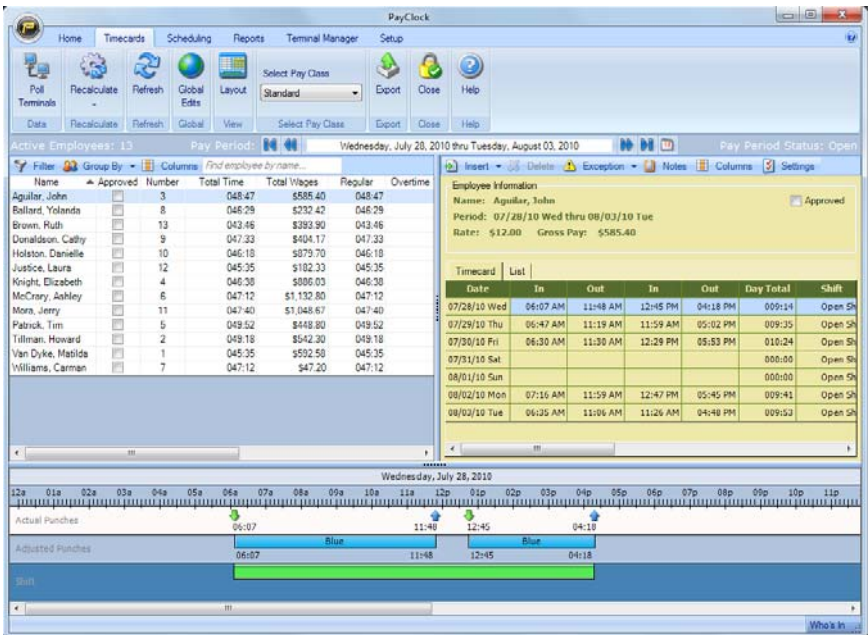

See the PayClock Help for detailed information on using the Timecard Tab.

Timecard Ribbon Bar

The Timecard Ribbon Bar has the following button groups; Data, Recalculate, Refresh, Global, View, Select Pay Class, Export, Close and Help as well as a status bar. You can poll the terminal(s), recalculate employee data, make adjustments globally to groups of

employees, select which Pay Class to edit the data for, select the time period for the edits, export payroll data and clock the pay period.

The Employee List and Toolbar

The Employee List displays employees along with their summary data such as wages, regular time, overtime, vacation, etc.

Name	Approved	Number	Total Time	Total Wages	Regular	Overtime 1	Overtime 2
Benedict, Frank	<input type="checkbox"/>	8	046:26	\$522.37	046:26		
Cunningham, Barbara	<input type="checkbox"/>	6	039:50	\$597.50	039:50		
Heard, Doris	<input type="checkbox"/>	9		\$0.00			
Jenkins, Nathan	<input type="checkbox"/>	3	054:02	\$162.10	054:02		

You can filter the employees that display in the list and define which columns display. You can also approve the employee timecards. Data can be viewed for open or closed pay periods.

When you highlight or select an employee in the list, the timecard on the right side of the window displays the data associated with the employee selected for the selected Pay Period. Use the Employee List to select an employee and the pay period navigation buttons to select the Pay Period.

The Employee List Toolbar allows you to filter and sort the list of employees as well as define the columns that display in the Employee List summary area.

You can also approve a timecard after finishing the edits. This will lock the employee's timecard and will not allow for any more edits. The approved option allows you to quickly see whose timecard edits have been finished and which employee(s) still need attention.

Filtering the Employee List

Click the Filter  Filter button to choose which employees you want to appear in the employee list. When you click the Filter button the Filter Options window will open. You can choose All Employees or departments that you created. You can also include or exclude inactive or terminated employees.

- Department - From the list select the department or departments that hold the employees you want to display in the summary list.
- Show Terminated Employees - Check this option if you want to display employees marked as terminated in the list. If you don't want terminated employees to display in the list, uncheck the option.
- Show Inactive Employees - Check this option if you want to display employees marked as inactive in the list. If you don't want inactive employees to display in the list, uncheck the option.

Using the Quick Search



Type a few letters of the desired employees name in the Quick Search field; all employees with those letters will display in the employee list. The full name or just a few letters can be entered in the “Find employee by name...” field.

Setting the Columns in the Employee List

Click the Columns  Columns button at the Employee List area to define the columns that will display in the Employee List. When you click the Columns button the Timecard Options window will open.

From the available columns, select what you want to display in the summary list by placing a check in the box. If you don't want a column to display in the summary list uncheck the box.

Note: The Name and Approved columns are fixed and can't be hidden or moved.

Employee Timecard and Toolbar

The Employee Timecard is used to view and edit an employees punch and non-work data. Use the Employee List to select an employee and the pay period navigation buttons to the select the pay period.

When an employee is selected from Employee List their individual timecard will display with their punch data for the selected pay period. The Timecard has 3 areas; the toolbar, the employee information and the timecard table.

The Timecard Toolbar allows you to add punches and non-work time, search for exceptions, insert notes and define the columns that display in the Timecard.

The Employee Information area displays the selected employee's name, the start and end of the selected pay period and the employee's hourly wage rate and gross pay. You can also Approve an employee's timecard. **Note:** The Employee Information area only displays when the timecard layout is set to "Side by Side".

The Timecard Table displays punch data and non-work time for the selected employee. You also use the table to edit data much like cells in a spreadsheet.

The screenshot shows the Employee Timecard interface. At the top is the **Timecard Toolbar** with buttons for Insert, Delete, Exception, Notes, Columns, and Settings. Below the toolbar is the **Employee Information** section, which displays the employee's name (Benedict, Frank), the selected pay period (08/16/10 Mon thru 08/22/10 Sun), and the hourly rate (\$11.25) and gross pay (\$0.00). There is also an 'Approved' checkbox. Below the information section is the **Timecard Table**, which is a spreadsheet-style table with columns for Date, In, Out, Day Total, and Regular. The table shows data for the dates 08/16/10 through 08/22/10.

Date	In	Out	In	Out	Day Total	Regular
08/16/10 Mon					000:00	000:00
08/17/10 Tue					000:00	000:00
08/18/10 Wed					000:00	000:00
08/19/10 Thu					000:00	000:00
08/20/10 Fri					000:00	000:00
08/21/10 Sat					000:00	000:00
08/22/10 Sun					000:00	000:00

Timecard and List Tabs

The Timecard Table has two tabs, Timecard and List.

Timecard tab - This tab is used for the typical editing and viewing of punch data.

List tab - This tab is designed specifically to be used to view the photos of employees who punch at the FaceIN terminal using the Card Verification method (Model FR700 only). The Card Verification method only requires that the employee present the badge and then the FaceIN terminal takes a snapshot of the person presenting the badge.

This allows the PayClock user to verify that the correct employee presented the badge and no buddy punching has taken place. See the sample below. To enlarge the photo, float the mouse over the image.

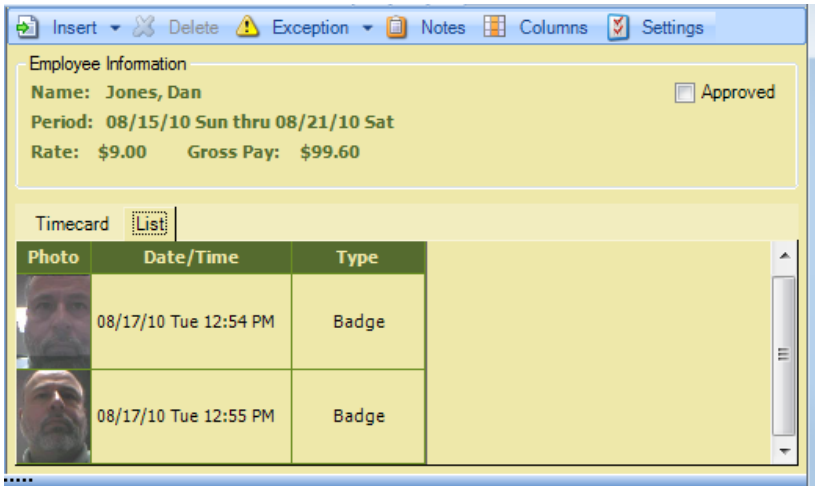

Timecard Table Color Legend

The timecard table can display the rows or cells in colors that are used to identify certain conditions.

- **Light Blue** - A row that is light blue identifies that the row is selected.

08/18/10 Wed	08:00 AM	12:00 PM	01:00 PM	05:00 PM	008:00	800-500
--------------	----------	----------	----------	----------	--------	---------

- **Light Red** - A light red cell identifies that there is an exception associated with the cell or the day. In this example the employee arrived late for their shift.

08/17/10 Tue	08:05 AM	12:00 PM	01:00 PM	05:00 PM	007:55	800-500
--------------	----------	----------	----------	----------	--------	---------

- **Olive Green** - Cells that are colored light green identify that the day contains a department transfer. Cells that are light green are disabled and do not allow punches.

08/18/10 Wed	08:00 AM	09:00 AM			001:01	800-500
08/18/10 Wed	09:00 AM	12:00 PM			004:00	800-500
08/18/10 Wed	01:00 PM	05:00 PM			008:00	800-500

Setting the Columns in the Timecard Table

Click the Columns  Columns button at the Timecard toolbar to define the columns that will display in the timecard. When you click the Columns button the Timecard Options window will open. You can define the columns that display in the Employee List or the columns that display in the Timecard or other timecard settings.

From the available columns select what you want to display in the summary list by placing a check in the box. If you don't want a column to display in the summary list uncheck the box.

Note: The Date, In, Out, In and Out columns are fixed and can't be moved. The Date, In, Out, In, Out and Regular columns can't be disabled.

Timecard Timeline

The Timecard Timeline is a snap-shot view of the shifts and punches for the selected date. The Timecard Timeline can be expanded, collapsed or hidden entirely. When the timeline is expanded it has 3 areas; the Actual Punches, the Adjusted Punches and the Shift.

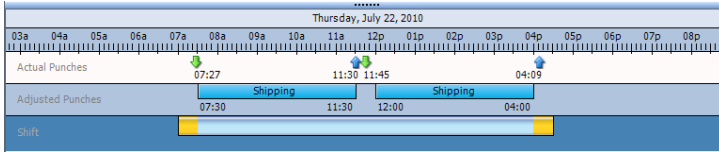

- **Actual Punches area** - Displays the unrounded punches.
- **Adjusted Punches area** - Displays the punches after they have been rounded.
- **Schedule area** - Displays the shift that is being used for the selected day.

The **open shift** will be represented by a green bar in the Schedule area.



An **assigned shift rule** will be represented by a light blue bar in the Schedule area. Note: In or Out revisions set up on the shift rule will be represented by a yellow area before (In revision) or after (Out revision) the light blue bar.



A **flexible shift rule** will be represented by a gray bar in the Schedule area.



Hiding the Timeline

The Timecard Timeline can be expanded or collapsed by clicking on the expanding/collapsing bar. The bar is located between the timecard table and timeline. It is identified in the red circle below.

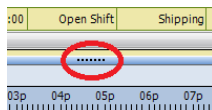

Maintaining Employee Timecards

The Timecards tab is used to manage employee punch data. You can view and edit employee punches as well as non-work time such as vacation time or dollar amounts such as tips.

The timecard body contains an area that resembles a spreadsheet for keying in punch data. **Note:** Manually added punches will show **bolded**.

Use the Employee List to select an employee and the pay period navigation buttons to select the Pay Period.

See the PayClock Help for detailed information on using the Timecard Tab.

Selecting an Employee

To select and open an employee's timecard click on the desired employee in the list and their timecard will display.

Selecting the Pay Period

Use the arrow  buttons on the Select Pay Period navigation bar of the Timecards tab to move forward or backward through the available pay periods until the desired time period is

displayed. You can also click the calendar  button which opens a window that allows you to choose from a list of pay periods.

Adding Punches - Timecard Table

You can add punches from within the timecard table and by using the Insert button on the timecard table toolbar.

- Select the Timecards tab on the ribbon bar and click on the desired employee from the Employee List, the employee's timecard will display.
- Click on the In or Out cell for the day when you want to add a punch. The cell will be highlighted when it has been selected.

- Type in the hour and the cursor will automatically move to the minutes.
- Type in the minutes and the cursor will automatically move to AM/PM.
- If your time is set to 12-hour format type an 'A' or 'P' to change to AM or PM.
- Press enter or tab on the computer keyboard to save the punch.

Adding Punches - Insert Button

You can use the Insert | Registration button to add a punch when there isn't an empty cell in the timecard table to key in a time.

- Select the Timecards tab on the ribbon bar and click on the desired employee from the Employee List, the employee's timecard will display.
- At the timecard table toolbar click the Insert button and select Registration, the Add Registration window will open.
- Type in the hour and the cursor will automatically move to the minutes.
- Type in the minutes and the cursor will automatically move to AM/PM.
- If your time is set to 12-hour format type an 'A' or 'P' to change to AM or PM.
- Enter the date for the punch.
- Click the Save and Exit button, the punch will be added to the timecard.

Adding Non-Work Time - Timecard Table

You can add non-work time from within the timecard table and by using the Insert button on the timecard table toolbar.

- Select the Timecards tab on the ribbon bar and click on the desired employee from the Employee List, the employee's timecard will display.
- Locate the non-work time column and then click on the cell for the day that you want to add the non-work time. The cell will be highlighted when it has been selected.
- Type in the amount of hours and minutes for the non-work time; use the right arrow key to move from hours to minutes.
- Press enter or tab on the computer keyboard to save the non-work time.

Adding Non-Work Time - Insert Button

You can use the Insert | Non-Work Time button to add a non-work time.

- Select the Timecards tab on the ribbon bar and click on the desired employee from the Employee List. The employee's timecard will display.
- At the timecard table toolbar, click the Insert button and select Non-Work Time. The Add Non-Work Time window will open.
- Enter the amount of non-work time at the Duration field, for example 8:00 for 8 hours.
- Select the pay code to apply the non-work time, for example vacation.
- Select the date to apply the non-work time.
- Click the Save and Exit button. The non-work time will be added to the timecard.

Adding Department Transfers - Timecard Table

A department transfer is when an employee stops working in one department and then begins working in another department.

- Select the Timecards tab on the ribbon bar and click on the desired employee from the Employee List, the employee's timecard will display.
- At the timecard table toolbar click the Insert button and select Transfer. The Add Transfer window will open.
- Type in the hour and the cursor will automatically move to the minutes.
- Type in the minutes and the cursor will automatically move to AM/PM.
- If your time is set to 12-hour format, type an 'A' or 'P' to change to AM or PM.
- From the list, select the department for the transfer.
- Click the Save and Exit button, the transfer will be added to the timecard.

Making a One-Time department change in the Timecard Table

You can make a one-time department change in an employee's timecard for a selected day or for a selected interval and keep all other days at their original department assignments.

If the Department column is displaying in the timecard table simply click in the cell for the desired day and from the list select the desired department. The department change will take affect immediately.

See the PayClock Help for detailed information on making a one-time department change in the timecard table.

Making a One-Time shift change in the Timecard Table

You can make a one-time shift change in an employee's timecard for a selected day and keep all other days at their original shift assignments.

If the Shift column is displaying in the timecard table, simply click in the cell for the desired day and from the list select the desired shift. The shift change will take affect immediately.

See the PayCLOCK Help for detailed information on making a one-time department change in the timecard table.

Adding Amounts - Insert Button

You can use the Insert | Amounts button to add an amount to the timecard. An amount could be considered a dollar value for example \$25 in tips.

- Select the Timecards tab on the ribbon bar and click on the desired employee from the Employee List. The employee's timecard will display.
- At the timecard table toolbar click the Insert button and select Amounts. The Add Amounts window will open.
- Click the New button.
- Select the date to apply the amount.
- Select the pay code to apply the amount for example Tips.
- Enter the amount for example 25.00 for \$25 dollars.
- Click the Save and Exit button. The amount will be added to the timecard, if you have the Tips column visible the amount will display in the column.

Adding a Timecard Note

The Timecard notes feature allows you to insert a text note for an employee on a specific day/date.

For example, John Doe called in sick on Monday so you might want to attach a note on John's timecard for Monday that he called in sick. Note: Timecard notes will also display on reports.

After a note is added a note symbol  will display on the date cell. To see the text of the note move the mouse over the symbol.

- At the Timecard toolbar click the Notes button, the Note Editor window will open.
- Enter the text for the note; up to 500 characters can be entered.
- Click the Save button, the note will be added and an icon  will display identifying a note is attached.

Using the Exception Filter

Exceptions are events that occur where PayClock will notify the user. User action may be required to resolve some exceptions, for example a missing punch. Other exceptions may not require any user action.

The PayClock software will highlight the timecard cell in red when an exception is found. You can click on the exception symbol  and a list of the exceptions will display. It will look like this example.

07/20/10 Tue	 07:35 AM	11:33 AM	12:00 PM	04:05 PM	007:55	730-400
Approve Arrived Late					000:00	730-400
Approve All					000:00	730-400

Once an exception is located you can approve or OK the exception if you wish. When an exception is approved you will see a green check  in the cell. It will look like this example.

07/20/10 Tue	 07:35 AM	11:33 AM	12:00 PM	04:05 PM	007:55	730-400
--------------	--	----------	----------	----------	--------	---------

To see which exceptions are approved select the cell with the green check  and then click Exceptions | View Exceptions... button.

Note: You can also remove the approval for an exception from the View Exceptions button.

See the PayClock Help for detailed information on using the Exception Filter.

Selecting the Exceptions

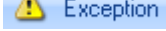
- At the timecard toolbar click the Exception  button and select Exception Filter, the Exception Filter window will open.
- Select the exception(s) you wish to view from the list. To view all exceptions click the Select All option.
- Click Save, your exceptions have been chosen.

Searching for Exceptions

- After selecting the exceptions to track select the first employee in the Employee List.
- At the timecard toolbar click the Exception  button and select Next Exception. This scans through the timecards moving forward in the employee list looking for exceptions. To scan backwards in the employee list select Previous Exception.
- PayClock will highlight the timecard cell in red once an exception is found. You can correct or approve the exception. Then click **Next Exception** to continue searching for additional exceptions. If none are found PayClock will display the message “No Exceptions Found”.

Using the List Tab of the Timecard Table

The Timecard Table has two tabs, Timecard and List.

Timecard tab - This tab is used for the typical editing and viewing of punch data.

List tab - This tab is designed specifically to be used to view the photos of employees who punch the FaceIN terminal using the Card Verification method. The Card Verification method only requires that the employee present the badge and then the FaceIN terminal takes a snapshot of the person presenting the badge.

This allows the PayClock user to verify that the correct employee presented the badge and no buddy punching has taken place. See the sample below. To enlarge the photo, float the mouse over the image.

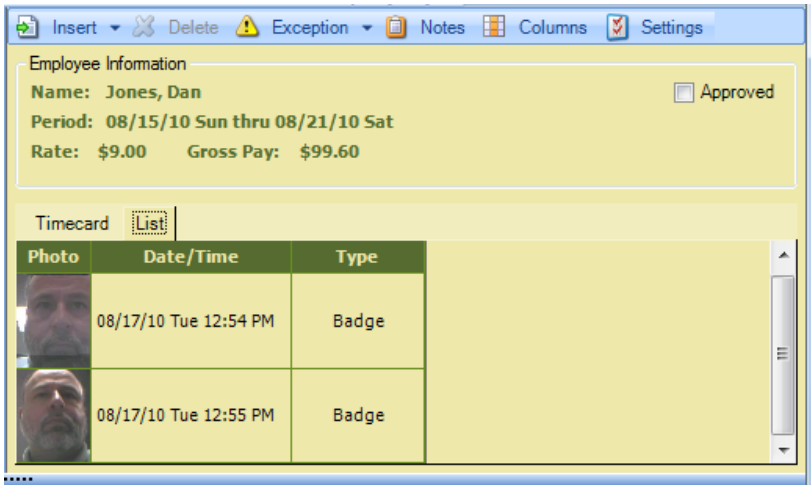

Viewing Photos of Employees Punching

The List tab is designed specifically to be used to view the photos of employees who punch the FaceIN terminal using the Card Verification method.

Note: Only photos for employees using the **Card** verification method will display in the List tab (Model FR700 only).

- Select the Timecards tab on the ribbon bar and click on the desired employee from the Employee List, the employee's timecard will display.
- Select the List tab in the timecard table, the employee's punches and associated photos will display in a chronological list.
- View the photos to verify that the correct employee made the punch.

Exporting Data

The Export button of the Timecards tab allows you to export your data to payroll. When you click the Export button a window opens with the exporting options you have setup at the Setup tab | Exports button.

The export process generates an export file in the format required by your payroll service and makes it available for your payroll software.

See the PayClock Help for detailed information on exporting data.

Creating an export file

- Select the Timecards tab and select the pay period by using the Pay Period navigation buttons.
- Click the Export button, the Execute Exports... window opens.
- Click on the desired payroll export in the list, there will be a check in the box when it has been selected.
- Click the Run Exports... button.

Closing the Pay Period

The Close button group contains the button which allows the user to close out the pay period. The close process “locks” the timecard data and no edits can be made. **Note:** You can not close a pay period if other users are logged into the PayClock software.

After you close the pay period you can still run reports and exports but you cannot edit the closed data. Make sure that you have finished making all your changes before closing your pay period.

Note: A closed pay period can be re-opened for the purpose of making a forgotten edit but caution should be used. Payroll rules may have changed since the pay period was closed and once a pay period

is re-opened it will be recalculated using the rules at the time of the re-open if changes are made to an employee's timecard data.

See the PayClock Help for detailed information on closing or re-opening a pay period.

Close the Pay Period

- Select the Timecards tab and click the Close button. The Select Pay Period window displays.
- Select the desired pay class and click OK.
- When the Close Procedures window opens verify that the dates for the pay period being closed are correct.

 **WARNING** - If you are not sure you want to close the pay period click **CANCEL**.

- Type the word **YES** in the box and click **OK** with your mouse.

Re-opening a Closed Pay Period

A closed pay period can be re-opened for the purpose of making a forgotten edit or change, but caution should be used. Payroll rules may have changed since the pay period was closed and once a pay period is re-opened it will be recalculated using the rules at the time of the re-open if changes are made to an employee's timecard data.

Important Note: When you re-open a closed pay period all other open pay periods will be temporarily closed and will not allow edits. Once the re-opened pay period is closed again the temporarily closed pay periods will go back to their normal open state and will allow edits.

- Select the Timecards tab. Using the Pay Period navigation buttons locate the closed pay period to be re-opened.
- The Close button will change to a Re-Open button.

- Click the Re-Open button. When the Re-Open Procedures window opens verify that the dates for the pay period being re-opened are correct.

 **WARNING** - If you are not sure you want to re-open the pay period click **CANCEL**.

- Type the word YES in the box and click the OK button with your mouse.
- The Pay Period Status will change to “Open For Edit” and all others will change to Closed.

Global Scheduling

The Scheduling tab presents a summary or snapshot of the estimated labor coverage in hours and dollars on a calendar. In addition the Scheduling tab is used to apply shifts to groups of employees, allowing shift assignments in mass rather than having to assign shifts to employees individually. These shift assignments will make up the employee's work schedule. You define the employee's work schedule in the calendar and assign shifts by date. A separate labor coverage chart is also available to view which allows for verification that there is enough labor coverage but not too much for a work day.

Scheduling Summary

The Summary window of the Scheduling tab presents a summary view or snapshot of the estimated labor coverage in hours and dollars on a calendar. A separate labor coverage chart is also available to view which allows for verification that there is enough labor coverage but not too much for a work day.

Global Shift Assignments

The Assign Shifts window of the Scheduling tab is used to apply shifts to groups of employees allowing shift assignments in mass rather than having to assign shifts to employees individually. These shift assignments will make up the employee's work schedule. You can define the employee's work schedule in the calendar and assign shifts by date. A separate labor coverage chart is also available to view which allows for verification that there is enough labor coverage but not too much for a work day.

To make global assignments of shifts simply press the **Go to Assign Shifts View** button. The workspace will open allowing shift assignments by groups of employees. To view the labor coverage summary again simply press the **Return to Summary View** button.

See the PayCLOCK Help for detailed information on Global Scheduling.

Reports

The Reports tab of the ribbon bar is used to obtain reports on the information that is stored in the database. When you click on the Reports tab you will see 3 areas; the Report Ribbon Bar, the Report Category List and the Report Toolbar with Viewer.

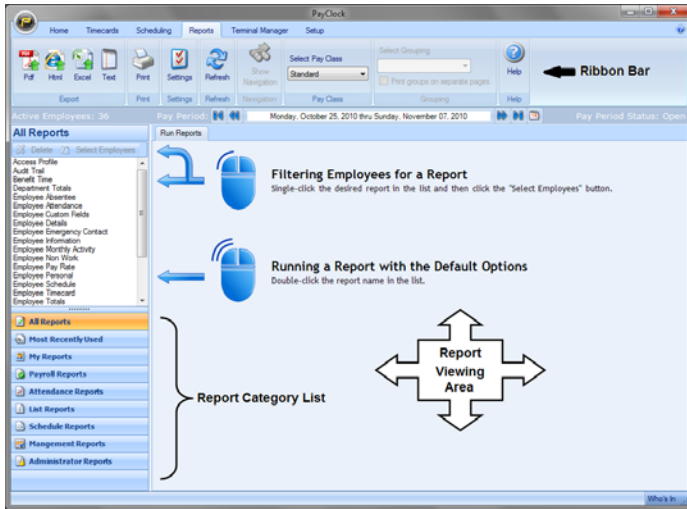

Running Reports

The Reports tab is used to view reports on employee data. The Reports Ribbon Bar has the following button groups; Export, Print, Settings, Refresh, Navigation, Pay Class, Pay Period, Grouping and Help. You can run reports on the open pay periods, closed pay periods or for a date range. **Note:** Certain reports allow you to drill down to see more detailed information.

The Report Category List area is where you choose which report you want to display in the viewer. The list of available reports is populated when a report category is selected. The available categories are; All Reports, Most Recently Used, My Reports, Payroll Reports, Attendance Reports, List Reports, Schedule Reports, Management Reports and Administrator Reports.

Including All Employees in the selected report

To view a report with all of the employees simply double click on the report in the list.

- Click the Reports tab on the ribbon bar and the Reports window will display.
- Double click on the report in the list you want to view.
- The report will show in the preview area with all employees.

Including certain Employees in the selected report

To select certain employees to include on a report single click on the desired report in the list and then click the Select Employees button and choose the desired employees.

- Click the Reports tab on the ribbon bar and the Reports window will display.
- Single click on the report in the list you want to view.
- Click the Select Employees button and the Select Employees window will open.
- Select the employee(s) to include on the report and click Show Report.
- The report will show in the preview area with the selected employee(s).

Selecting the Pay Period for the report

- Select and preview the desired report.
- Choose the pay period for the report by clicking the Pay Period navigation buttons. You can select any open or closed pay period.

<p>See the PayClock Help for detailed information on running Reports.</p>
--

Setting up your Terminal

The Terminal Manager tab of the ribbon bar is used to maintain the terminals used to collect punch data. When you click on the Terminal Manager tab you will see 3 areas; the Terminal Manager Ribbon Bar, the Terminals List and the Terminal Properties and Toolbar.

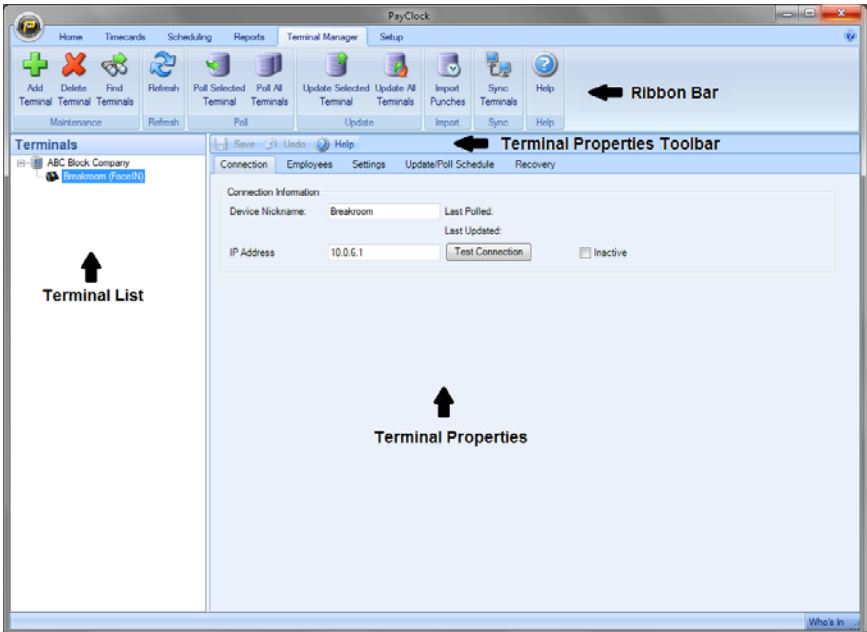

The Terminal Properties and Toolbar

The Terminal Properties is used to view and edit the configuration of a terminal using five tabs, Connection, Employees, Settings, Update/Poll Schedule and Recovery.

Adding a FaceIN Terminal

- Select the Terminal Manager tab on the ribbon bar and click the Add Terminal button. The Select Terminal Type window will open.

- Select the desired FaceIN model from the drop down list and click OK.
- The FaceIN terminal properties will display on the right.
- From the Connection tab enter the name for the terminal under Device Nickname.
- Enter the IP Address in the field, this is the address that was set up on the FaceIN terminal, click Save.
- Click the Test Connection button to verify communications with the FaceIN terminal.
- Select the Settings tab and click the Set button to send the time/date to the terminal.

Connection tab - FaceIN Terminal

The Connection tab allows you to define the name and the IP address for the terminal.

Employees tab - FaceIN Terminal

The Employees tab is used to assign employees to a terminal and to un-assign employees from a terminal. Note: Employees are automatically assigned to the terminal. If you wish not to have new employees automatically assigned to the terminal select the option “Do not automatically assign new employees to this terminal”.

Removing Employee Assignments

1. From the Ribbon Bar, click the Terminal Manager tab and select the desired terminal from the list. The Terminal properties window will display.
2. Click on the Employees tab, from the list on the **right** select the desired employees and click the Remove button. The employees will be removed from the list. Click Save

3. Click Update Selected Terminal to send the changes to the terminal.

Assigning Employee

- From the Ribbon Bar, click the Terminal Manager tab and select the desired terminal from the list. The Terminal properties window will display.
- Click on the Employees tab, from the list on the **left** select the desired employees and click the Add button. The employees will be added to the list. Click Save
- Click Update Selected Terminal to send the changes to the terminal.

Settings tab - FaceIN Terminal

The Settings tab is used to set the time and date, volume, etc. There are six areas, Date and Time, General Settings, Password, Power Save, Feature Settings and Update Settings.

Date and Time

This area is used to send the time and date to the terminal.

Set Terminal Date and Time: Click the Set button to send the time and date to the terminal.

Terminal Volume

This area is used to adjust the volume at the terminal. The default is Medium.

Feature Settings

This area is used to set how long the registrations are stored on the FaceIN terminal.

Maximum days to store registrations on terminal: Select how many days to store punches in the terminals memory. The default setting is 90 days.

Update/Poll Schedule tab - FaceIN Terminal

The Update/Poll Schedule tab allows you to set up auto polling of the terminal.

Enable Auto-Poll for this terminal - Select this option if you want to turn on auto poll for the terminal.

Poll clock every - Select how often to automatically poll the terminal.

Beginning at ___:___ until ___:___ - Enter the time to start and end the automatic polling.

Poll Clock at these specific times - Select this option is you want to schedule a specific time of the day to automatically poll the terminal.

Poll Times - Select the specific time to automatically poll the terminal.

Add - Click the Add button after setting the Poll Time.

Remove - To delete a Poll Time that has been set, select it from the list and click the Remove button.

Schedule Active on the Following Days - Select which days of the week that the automatic polling will run.

Recover tab - FaceIN Terminal

The Recovery tab is used to recover punch data from the terminal in the event of data loss at the computer. The Recover tab will also allow the reset of the Administrators that are configured at the terminal.

Recover Terminal (button) - Click this button to initiate a recovery of all data in the terminal.

Reset Admin Accounts (button) - Click this button to remove any admin accounts set up on the terminal. Typically this would be used if the person or persons who were registered as the administrator are no longer available to access the terminal. After resetting the administrator accounts, a new administrator should be set up at the FaceIN terminal, otherwise any person can approach the terminal and press the MENU button and gain access to the terminals settings.

See the Online Help for detailed information on the Terminal Manager tab.

Update the Terminal

When you add an employee to PayClock they are automatically assigned to the FaceIN terminal(s). But before you can enroll the employee faces at the terminal you will have to update the terminal with the changes.

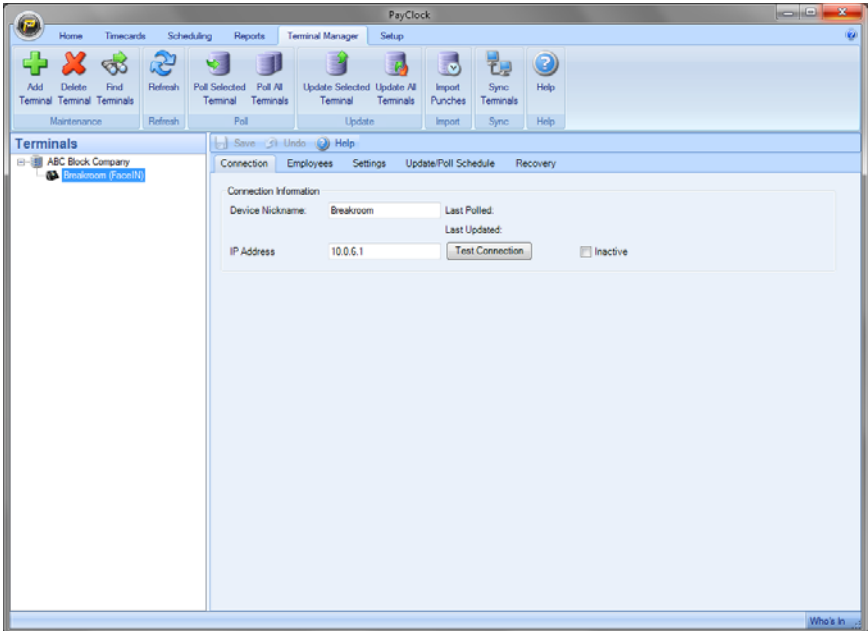

1. From the Ribbon Bar, click the Terminal Manger tab. The Terminal Manager window will open.
2. Click Update All Terminals or select the desired terminal from list and click Update Selected Terminal.
3. The employees created in PayClock will be sent to the terminal(s) and you will be ready to enroll the employee's face.

Polling the Terminal

When you poll a terminal, you retrieve the punch information from the terminal and the punches are placed in the database making the data available in the PayClock software. It's a good practice to poll your terminal everyday or even better, activate the automatic polling.

If you can't poll everyday, you should poll the terminal before making any edits in the PayClock software. By polling everyday or before making any edits, you can be sure you are working with the most current data.

Polling from the Timecards Tab

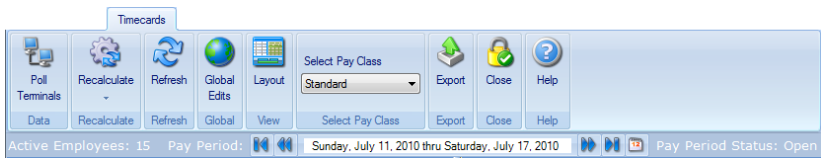

The Data button group contains the Poll Terminals button, which will poll the terminal(s) connected to the PayClock system.

1. Select the Timecards tab on the ribbon bar and click on the Poll Terminals button.
2. Click Poll button or select the desired terminal from list and click Poll button.
3. The punch data will be retrieved from the terminal and added to the database.
4. You are now ready to view, modify or report on the polled data.

See the next section “Automatic Polling” for detailed information on setting up the automatic polling of FaceIN terminal.

Automatic Polling

PayClock allows you to set up automatic polling of the FaceIN terminal(s). With automatic polling you are always working with the most current punch data.

Activating the Automatic Polling

1. Open the PayClock software and select the Terminal Manager tab.
2. Select the desired terminal from the list, the terminals properties will display as a set of tabs on the right.
3. Click on the **Update/Poll Schedule** tab.
4. Select the **Enable Auto-Poll for this terminal** option.

To poll every X minutes:

- Select the “Poll Clock every...” option.
- From the list choose to poll the clock every 1, 2, 3, 4, 5, 10, 15, 30, 45 or 60 minutes.
- Set the time to begin the polling for the selected day(s), the default is 8:00am.
- Set the time to end the polling for the selected day(s), the default is 8:00pm.
- Select the days of the week to have the auto-poll active, the default is Monday through Friday.
- Click Save, the automatic polling will activate on the desired day(s) at the minutes selected.

To poll specific times:

- Select the “Poll Clock at these specific times” option.
- Set the first time the poll is to happen and click the Add button.
- Continue adding the times the poll is to happen.
- Select the days of the week to have the auto-poll active, the default is Monday through Friday.
- Click Save, the automatic polling will activate on the desired day(s) at the times defined.

Hardware Troubleshooting

The following section contains common questions and problems as well as their appropriate resolutions.

To view a complete list of common problems and their solutions please visit our knowledge base located online at:
<http://support.lathem.com>

Issue	Resolution
<p>I can't communicate with the FaceIN terminal.</p>	<ul style="list-style-type: none"> -Make sure that all connections are secure and the cables are intact. -Make sure that the network cable is securely connected to the Ethernet port on the terminal. -Make sure that the terminal's power supply is securely connected to the electrical outlet and back of the terminal. -Make sure the network communication settings are correct at the terminal, to check the settings: <ul style="list-style-type: none"> • At the FaceIN terminal, press the MENU key, administrator verification is required. The Functions Menu will open. • Press 5, the System Info menu will open. • From the System Info menu, press 2-Product Info. • Verify the addresses for the IP, Mask and Gate. • To exit press ESC. <p>Note: If changes are needed, from the Functions Menu press 4-System Setting and then 2-Set Network. Make the needed adjustments and press OK to save the changes.</p> -Make sure the network communication settings are correct in the PayClock software, to check the settings: <ul style="list-style-type: none"> • Open PayClock and click on the Terminal Manager tab. • Select the FaceIN terminal from the list; verify that the IP address on the Connection tab matches what was configured at the terminal. <p>-If after going through each item above you are still</p>

	not communicating with the terminal, have the network administrator or IT person make sure there aren't any issues with the network.
When an employee presents their face it is not recognized.	-If the employee's facial appearance has changed, re-enroll the employee. -Make sure the employee is presenting their face within range of the terminal, within 9 - 25 inches of the front of the terminal.
How do I reboot/restart the FaceIN terminal?	-Disconnect the AC power, wait a few seconds and reconnect. -Press the RESET button on the bottom of the terminal.
How do I clean the FaceIN terminal?	Use only a soft cloth or similar material to clean the screen and front of the terminal. Avoid using water or cleaners!
Is the FaceIN terminal waterproof?	NO, the terminal is not waterproof! Make sure you keep the terminal away from water or a wet/damp environment.
Can I place the FaceIN terminal outside?	It is not recommended to place the terminal in a low temperature environment. The working temperature for the display and other parts in the terminal are normal indoor temperatures.

Software Troubleshooting

The following section contains common questions and problems as well as their appropriate resolutions.

To view a complete list of common problems and their solutions please visit our knowledge base located online at:
<http://support.lathem.com>

Issue	Resolution
What is the password to login to the software?	The default password is "lathem". If you have changed the default password, and can't remember your new password, contact the help desk for assistance in resetting your password.
How do I add a missing punch?	See page 52 - Maintaining Employee Timecards.
How do I export pay period data?	See page 60 - Exporting Data.
How do I close a pay period?	See page 60 - Closing the Pay Period.
How do I change PayClock to a multi-user system?	See page 28 - Setting up a Multi-User System.
How do I re-open a closed pay period?	See page 61 - Re-Opening a Closed Pay Period.
How do I set PayClock to automatically poll the FaceIN terminal?	See page 73 - Automatic Polling.

Appendix A - Exporting Punches to a USB Drive

The USB Functions menu allows you to export punch data to a USB thumb drive and then import the data into the PayClock database using the PayClock software.

Important Note: If you don't have an Ethernet connection, you can transfer punch data from the terminal to the PayClock software using a standard USB thumb drive.

Export the data to USB Thumb Drive

- At the FaceIN terminal, press the **ESC** key to force the terminal to the normal time/date screen.
- Insert the USB Flash drive into the USB port on the bottom of the terminal, administrator verification is required.
- The administrator should present and position their face for a facial scan. The Functions Menu will display upon a successful verification.

Note: Due to compatibility issues, not all USB Flash drives are compatible and may not work with the terminal. It is not recommended to use a USB Flash drive formatted as NTFS

- Press **1** or select the Export Records menu and press **OK**.
- When the export is complete the data will be saved to a file named TIME .TXT (there are 3 spaces between TIME and .TXT) on the root of the USB Flash drive.
- After a few seconds, the system will return to the "Functions Menu" screen.
- Press the **ESC** key, the terminal will return to the normal time/date display.
- Unplug the USB Flash drive.

Import the data into PayClock

- Plug the USB Flash Drive into a USB port on your computer.
- Open PayClock and select the Terminal Manager tab on the ribbon bar. The Terminal Manager window will open.
- Click on a FaceIN terminal in the list, the Import Punches button will become active.
- Click the Import Punches button, the Open window will display.
- Navigate to the location of the TIME .TXT file, typically located on the USB Flash Drive plugged into your computer.
- Click the Open button, the punch data will be imported into the PayClock database.

Appendix B - Adding Employees at the Terminal

Employees can be added at the FaceIN terminal first and then added in the PayClock software later. This could be useful when a new employee starts work before having a chance to add them to the PayClock software.

Important Note: The number you enter for the User No. at the FaceIN terminal has to match what is entered for the Employee PIN Number in the PayClock software. These numbers are how the software identifies which punches go with which employee.

You should follow these recommended steps if adding the employees at the FaceIN terminal.

1. Add and enroll the employee's face at the FaceIN terminal.
2. Have the employee punch In and Out.
3. Add the employee in the PayClock software **before** polling and processing payroll.

Adding an Employee at the FaceIN Terminal

- At the FaceIN terminal, press the MENU key, administrator verification is required.
- The administrator should present and position their face for a facial scan. The Functions Menu will display upon a successful verification.
- Press **2** or select the User Management menu and press **OK**.
- Press **1** or select the Register User menu and press **OK** to add a new employee at the terminal.
- The Input User No. screen will display.
- Using the index/numeric keys, enter the User Number and press **OK**. **Note:** This is the number that will be entered into the PayClock software as the employees PIN number. The number has to be unique.
- The Input Name screen will display.

- Using the index/numeric keys enter a name. This should be the same as the first name you will enter into the PayClock software. After pressing the desired index/numeric key, use the ↑/↓ to move through the available letters. To change to caps, press the index/numeric key with the desired letter and press the **ESC** key. The letter group will change to caps. After entering the name, press the **OK** key.
- With the employee standing at the ready, select the verification method to use for the employee.

Verification Methods

Typically for a normal employee you would select Face recognition, for a temporary employee select Card recognition, for higher security select either Pin and Face or Card and Face recognition.

Face / PIN & Face Verification Method

When enrolling employee faces, take the following into consideration:

Eye Glasses - It is recommended for the employee to enroll with the eye glasses on for half the process, then remove the eye glasses and complete the registration.

Hair Style - If the employee has a hair style that has their hair covering or blocking their eyes, move the hair away from the eyes during the registration process.

- Position the employee so the face is in the middle of the two cameras with 9 to 25 inches between the face and the terminal.
- The image collecting screen will display, start the face recognition enrollment.
- Perform 2 small head circles to the right.
- Perform 2 small head circles to the left.
- Move the face closer to the terminal until the white dashed square appears.

- Move the face back until there is 9 to 25 inches between their face and the terminal.
- Turn the head fully to the right.
- Turn the head fully to the left.
- Raise the head up slightly.
- Lower the head down slightly.
- Move the face back from the terminal until there is 9 to 25 inches between the face and the terminal (if adjust positioning message is still displaying).
- Resume small head circles to the right (if adjust positioning message is still displaying).
- The progress bar at the bottom of screen will display the process of the imaging.
- When the face is enrolled the terminal will display, “Permit Open Door?” press **ESC**.
- When “Permit Attendance?” displays, press **OK**. Note: You must press OK; otherwise punches will not be recorded for polling.
- The screen will display “Finished” and will return to the “Input User No” screen. Continue with the next employee or press **ESC**, **ESC** and **ESC** again to return to the normal time/date screen.

Card Verification Method (FR700 only)

- When “Please Swipe Card” displays, present the card at the terminal.
- When the card is enrolled the terminal will display, “Permit Open Door?” press **ESC**.
- When “Permit Attendance?” displays, press **OK**. Note: You must press OK; otherwise punches will not be recorded for polling.
- The screen will display “Finished” and will return to the “Input User No” screen. Continue with the next employee or

press **ESC**, **ESC** and **ESC** again to return to the normal time/date screen.

Card & Face Verification Method (FR700 only)

When enrolling employee faces, take the following into consideration:

Eye Glasses - It is recommended for the employee to enroll with the eye glasses on for half the process, then remove the eye glasses and complete the registration.

Hair Style - If the employee has a hair style that has their hair covering or blocking their eyes, move the hair away from the eyes during the registration process.

- When “Please Swipe Card” displays, present the card at the terminal.
- Position the employee so the face is in the middle of the two cameras with 9 to 25 inches between the face and the terminal.
- The image collecting screen will display, start the face recognition enrollment.
- Perform 2 small head circles to the right.
- Perform 2 small head circles to the left.
- Move the face closer to the terminal until the white dashed square appears.
- Move the face back until there is 9 to 25 inches between their face and the terminal.
- Turn the head fully to the right.
- Turn the head fully to the left.
- Raise the head up slightly.
- Lower the head down slightly.
- Move the face back from the terminal until there is 9 to 25 inches between the face and the terminal (if adjust positioning message is still displaying).

- Resume small head circles to the right (if adjust positioning message is still displaying).
- The progress bar at the bottom of screen will display the process of the imaging.
- When the face is enrolled the terminal will display, “Permit Open Door?” press **ESC**.
- When “Permit Attendance?” displays, press **OK**. Note: You must press OK; otherwise punches will not be recorded for polling.
- The screen will display “Finished” and will return to the “Input User No” screen. Continue with the next employee or press **ESC**, **ESC** and **ESC** again to return to the normal time/date screen.

Appendix C - Connecting the FaceIN Directly to the Computer's NIC

This document describes the steps to configure FaceIN terminal to communicate with the PayClock database server when connecting directly into the computers wired NIC. This would be used when the user doesn't have a network setup and has a computer that has a wired NIC.

Step #1 - At the Computer where PayClock is installed

See the More Information section for Windows XP, Vista and Windows 7 directions for accessing the NIC properties.

- Open the Properties of the NIC.
- Open the Properties of the Internet Protocol item.
- Define the IP (10.0.1.1) and Subnet Mask (255.0.0.0).

Step #2 - Connect the Ethernet cable to the computer and FaceIN

- The computer will go through the process of acquiring the IP connection.

Step #3 - At the FaceIN terminal

- Press the **MENU** key, the Functions Menu will open.
- Press **4**, the System Setting menu will open.
- From the System Setting menu, press **2 - Set Network**.
- Enter the IP Address for the terminal (using the computer's IP as reference, i.e. 10.0.1.2) and press **OK**.
- Enter the Mask (same as what was entered at the pc, i.e. 255.0.0.0) Code and press **OK**.
- Leave the Gateway at the default (blank) and press **OK**.
- Enter the Host computers IP address and press **OK**. (FR650 Only).
- The FaceIN terminal will restart automatically.

Note: You may have to enter leading zeros when entering the addresses. For example, the address **10.0.0.1** would be entered as **010.000.000.001** at the terminal.

Step #4 - At the PayClock software

- Open the PayClock software and click on the Terminal Manager tab.
- Click the Add Terminal button and select FaceIN.
- Enter the IP address given to the FaceIN in the IP Address field.
- Click Save.
- Click the Test Connection button and verify the communications.

More Information:

To access the NIC settings follow the steps for the appropriate Windows operating system:

Windows XP

- Click Start > Control Panel > Network Connections.
- Right click on the desired connection in the list and select **Properties**.
- Select the **Internet Protocol (TCP/IP)** item.
- Click the **Properties** button.
- Choose **Use the following IP address**.
- Enter the values outlined in this document.
- Click **OK** and then click **Close**.

Windows Vista

- Click Start > Control Panel > Network and Internet | View Network Status and Task > Manage Network Connections.
- Click on **Manage Network Connections**.
- Right click on the desired connection in the list and select **Properties**.
- Click **Continue** on the User Access Control message.
- Select the **Internet Protocol Version 4 (TCP/IPv4)** item.

- Click the **Properties** button.
- Choose **Use the following IP address**.
- Enter the values outlined in this document.
- Click **OK** and then click **Close**.

Windows 7

- Click Start > Control Panel > Network and Internet | View Network Status and Task > Manage Network Connections.
- Click on **Change Adapter Settings**.
- Right click on the desired connection in the list and select **Properties**.
- Select the **Internet Protocol Version 4 (TCP/IPv4)** item.
- Click the **Properties** button.
- Choose **Use the following IP address**.
- Enter the values outlined in this document.
- Click **OK** and then click **Close**.

Appendix D - Access Control

Note: Access Control is only available in the FR700 model.

Use the FR700's internal access control relay to integrate with a facilities entry access control system.

Important Note: When enrolling an employee make sure to select **OK** at the **Permit Open Door?** prompt.

Terminal Access Control Relay Connector Configuration

This table identifies the terminals connection points.

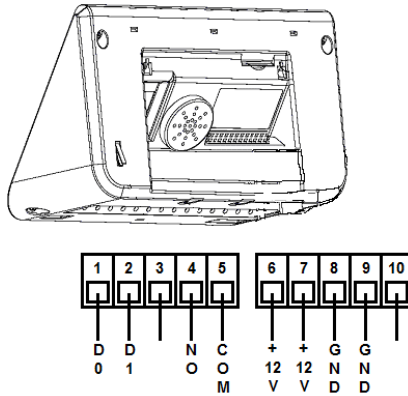

1 = D0 - Output to Wiegand Controller	6 = +12V - 12 volt output to external device
2 = D1 - Output to Wiegand Controller	7 = +12V - 12 volt output to external device
3 = Not Used	8 = GND - Ground connection
4 = NO - Normally open internal dry contract relay output	9 = GND - Ground connection
5 = COM - Common output for internal dry contract relay	10 = Not Used

Connecting the Terminal to an Electromagnetic Lock

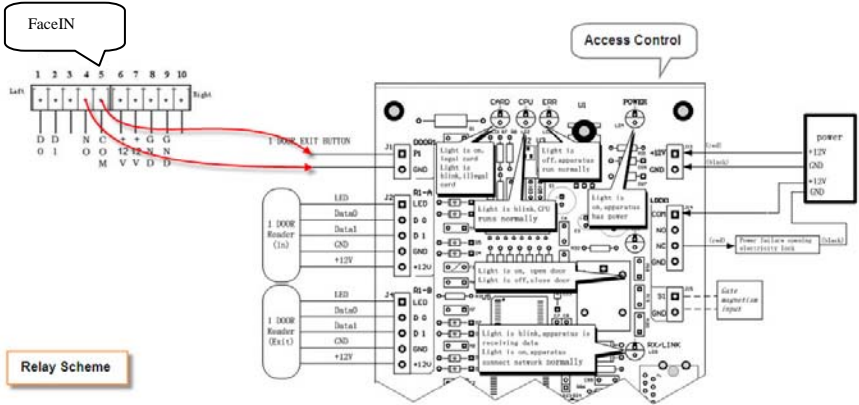

Connecting the Terminal to an Electromagnetic Lock using a Wiegand Signal

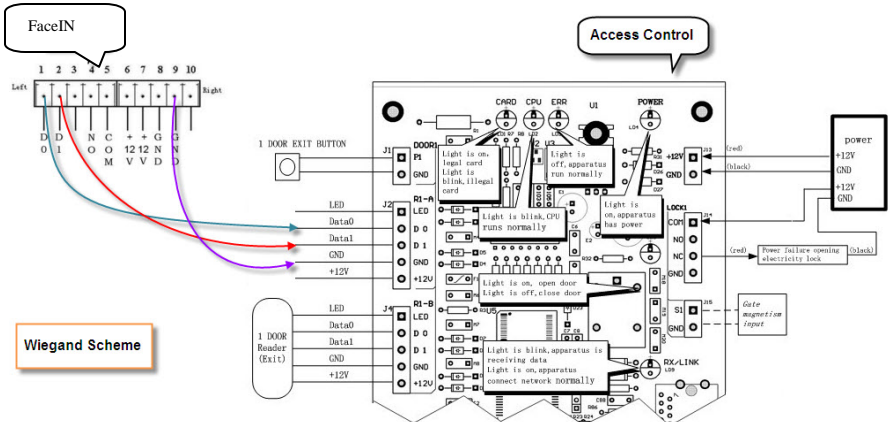

Terminal 26-Bit and 34-Bit Wiegand Formats

Wiegand 26:

0 1- Site Code -8 9--- User ID ---24 25bit

X 0 1 1 0 0 1 0 0 X X X X X X X X X X X X X X X X X

Site Code for Terminal : 100 (8 bits)

User ID: 1-65536 (16 bits)

Wiegand 34:

0 1- Site Code -8 9--- User ID ---32 33-bit

X 0 1 1 0 0 1 0 0 X

Site Code for FaceIN : 100 (8 bits)

UserID: 1-16777216 (24 bits)

Appendix E - Integrating PayClock with QuickBooks

The integration between PayClock and QuickBooks allows the user to enter the employees into QuickBooks and then synchronize them into PayClock. The export process allows PayClock to send employee total daily hours into the QuickBooks weekly timesheet. Here are some important points to remember:

- Only QuickBooks 2009 and later are supported.
- QuickBooks and PayClock must be installed on the same computer.
- PayClock cannot export an output file that can be imported into QuickBooks

Follow these steps to set up the integration between PayClock and QuickBooks

- Open QuickBooks in **Single User Mode** with Administrator access.
- With PayClock open, click the Setup tab.
- Click the Exports button, the Exports window will open.
- Click New and select Standard: QuickBooks 2009 or Later.
- Click the Setup Export button and the Export Wizard will open.
- Select the Pay Class desired and click Next.
- Click Next again and the QuickBooks Integrated Application window will open.
- Select **Yes, always; allow access even if QuickBooks is not running.**
- Check the option **Allow this application to access personal data such as Social Security Numbers and customer credit card information.**

NOTE: If the above two options are not selected the integration process will fail!

- Click Continue and then click Done.
- In PayClock click Next.
- Map the QuickBooks Payroll Items to the PayClock Pay Codes.
- When finished mapping the payroll items click Next.
- If desired select the Send Employee pay rates from QuickBooks to PayClock. Click Next.
- If Classes are set up in QuickBooks map the QuickBooks Classes to the PayClock departments. Click Next.
- Give the export a unique name if multiple pay classes are to be set up to integrate with QuickBooks. For example give it the name of the pay class it is linked with.
- Click Finish. PayClock will synchronize with QuickBooks and will display the Resolve Employee Conflicts window.
- At the Resolve Employee Conflicts window match QuickBooks employees to PayClock employees.
- Choose Create New Employee for any hourly employee not listed in PayClock.
- For salaried employees, choose Import as Inactive.
- Click Save.

Once the export is configured PayClock will automatically get any new employees or edited employees from QuickBooks when PayClock is opened.

At the end of the pay period click the Export button on the Timecard tab to send the pay data hours from PayClock to QuickBooks.

Appendix F - FaceIN WAN Installation

These instructions identify the steps to configure the FaceIN terminal to communicate with the PayClock database server across the internet.

A print out of the “Server Summary” information is required for this set up. If the information was not printed during the PayClock software installation follow these steps to access the information.

- At the computer where the PayClock database server resides, open the PayClock software.
- Click the PayClock orb on the upper left and from the menu, select **Support Assistant**.
- In the Support Assistant window select *Connection Info*.
- Print the Connection_Info.txt file for use when configuring the FaceIN.

WAN Installation Requirements

- There must be a VPN tunnel connecting the local and remote sites.
- A static IP address is **required** on the computer designated as the PayClock database server.
- A network administrator may be required to configure the network routers to route the ports used by the FaceIN terminals and PayClock database server.

Important Port Information - The following ports are used for this type of installation.

- 7350 - PayClock Network Terminal Service
- 7351 - Auto Poll Service
- 2638 - PayClock Database Server

FaceIN WAN Installation

- At the remote site install mount and connect the FaceIN terminal to the network.
- With the FaceIN powered up and connected to the network, press the **MENU** key, the Functions Menu will open.
- Press **4**, the System Setting menu will open.
- From the System Setting menu, press **2 - Set Network**.

Note: You may have to enter leading zeros when entering the addresses. For example, the address **10.0.0.1** would be entered as **010.000.000.001** at the terminal.

- Enter the IP Address for the terminal and press **OK**. **Note:** This is the IP address from where the FaceIN terminal will reside at the remote site.
- Enter the Mask Code and press **OK**. **Note:** This is the subnet Mask address from where the PayClock database computer resides. Refer to the **Connection Info** print out.
- Enter the Gateway Address and press **OK**. **Note:** This is the Gateway address from where the PayClock database computer resides. Refer to the **Connection Info** print out.
- Enter the Host computers IP Address and press **OK**. (FR650 only) **Note:** This is the IP address of the PayClock database computer. Refer to the **Connection Info** print out.
- The FaceIN terminal will restart automatically.
- To verify the connection open PayClock, select the Terminal Manager tab and click the Test Connection button.
- The FaceIN terminal will be operational.
- Update the FaceIN terminal and enroll the employee faces.

Appendix G - PayClock Client Software WAN Installation

These instructions identify the steps to configure the PayClock Client software to communicate with the PayClock database server across the internet.

Important Notes - WAN Installation Requirements

- There must be a VPN tunnel connecting the local and remote sites.
- The network administrator may be required to configure the network routers to route the ports used by the PayClock Client and PayClock database server.
- A static IP address is **required** on the computer designated as the PayClock database server.
- PayClock **must** be licensed as a “Multi-User” system, additional license fees may apply.

Important Port Information - The following ports are used for this type of installation.

- 7350 - PayClock Network Terminal Service
- 7351 - Auto Poll Service
- 2638 - PayClock Database Server

Step #1 - Computer where the PayClock database server will reside

- Install the PayClock Server (Standard Install).
- Print out the “Server Summary” information. Note: If the “Server Summary” information was not printed during the installation follow these steps to access the information:
 - Open the PayClock software.
 - Click the PayClock orb on the upper left.

- From the menu select **Support Assistant**.
- In the Support Assistant window, select **Connection Info**.
- Print the Connection_Info.txt file.

Step #2 - PayClock Client at the remote site

- **Run the PayClock Setup Program**
 - Go to the computer where you want to install the PayClock client.
 - Make sure your screen saver is not showing before inserting the PayClock CD.
 - Insert the PayClock CD-ROM in the CD-ROM drive. Note: If you are installing on Windows Vista or Windows 7 you may have to click Allow, Continue or Yes at the User Account Control confirmation window.
 - The Setup program should run automatically. If not follow the steps below.
 - Click **Start | My Computer** or **Computer**.
 - Double click on the drive that contains the PayClock installation CD.
- **Follow the Setup Steps**
 - It may take the install a few minutes to start, please be patient.
 - From the Install PayClock window click on **Next**.
 - Read the License Agreement and select **I accept the terms of the license agreement** and **Next** to move forward.
 - Select the Custom option and click **Next** to continue.

- At the Install on Single PC or Network window select **I need multiple computers that can run PayClock** and click **Next** to continue.
- At the Install Client Only or Client & Server window select **Client Only** and click **Next** to continue.
- **Enter the Server Information**
 - The **Select Server** window will open with the message, “We were unable to locate any PayClock servers on your network. Please enter the server information.”.
 - Enter the Database Server Name in the field. **Note:** Use the Server Summary or Connection Info print out for the PayClock database server’s name.
 - Enter the Database server’s IP address in the field. **Note:** Use the Server Summary or Connection Info print out for the PayClock database server’s IP address.
 - Click **Next** to continue.
 - At the Ready to Install screen click **Next**.
 - At the Installation Complete screen click **Finished**.

Step #3 - Open PayClock at the remote site

- Open the PayClock software to verify the connection.

A

- Access Control, 87
- Accessories, 3
- Add the FaceIN terminal, 39
- Adding a FaceIN, 66
- Adding a New Employee, 41
- Adding a Note, 56
- Adding Amounts, 56
- Adding Employees, 40
- Adding employees at the terminal first, 79
- Adding Non-Work Time, 53, 54
- Adding Punches, 52, 53
- Annual Support Agreements, 5

B

- Benefit Time Tab, 44

C

- Card & Face Verification, 18
- Card Verification, 18
- Clocking In & Out, 20
- Clocking IN/Out - Card & Face Verification, 22
- Clocking IN/Out - Card Verification, 22
- Clocking IN/Out - Face Verification, 20
- Clocking IN/Out - PIN & Face Verification, 21
- Closing the Pay Period, 60
- Connecting FaceIN directly to pc's NIC, 84
- Connection Tab - FaceIN, 67

D

- Department Tab, 44

Department Transfers - Adding, 54

E

Editing Timecards, 45

Employee

PIN, 42

Employee Advanced Tab, 44

Employee Button, 40

Employee List and Toolbar, 46

Employee Number, 42

Employees Tab - FaceIN, 67

Enrolling Employee Faces, 15

Enrollment Guidelines, 15

Exception Filter, 57

Exporting Data, 60

Exporting punches to a USB drive, 77

F

Face & PIN Verification, 17

Face enrollment guide, 13

FaceIN Startup, 10

FaceIN WAN Installation, 92

Features & Specifications, 2

Filtering the Employee List, 46

G

Global Scheduling, 63

H

Hardware Troubleshooting, 74

Help, 3

Home Department, 42

Home Tab, 30

How the FaceIN works, 1

I

Install the PayClock Software, 24

Installing the FaceIN, 8

Integrating PayClock with QuickBooks, 90

L

List Tab - Timecard, 49

Logging In, 31

M

Maintaining, 52

Messages Tab, 44

Minimum PayClock Set up, 34

O

One-Time Department Change, 55

One-Time Shift Change, 55

Overrides Tab, 43

Overtime, 35

P

Package Contents, 6

Password, 32, 76

Pay, 35

PayClock Client Installation, 26

PayClock Client Software WAN Installation, 94

PayClock orb, 30

Personal Tab, 44

Polling the FaceIN, 72

Product Overview, 1

Purpose of this User's Guide, 1

R

Recover Tab - FaceIN, 70
Registering PayClock, 32
Re-opening a closed pay period, 61
Reports, 64
Reports Tab, 30
Rounding, 36
Running Reports, 64

S

Salaried Employees, 42
Schedules Tab, 43
Scheduling Tab, 30
Searching for Exceptions, 58
Selecting an Employee in the Timecard, 52
Selecting Exceptions, 58
Selecting the Pay Period in the Timecard, 52
Setting the columns in the Employee List, 47
Setting the columns in the Timecard, 50
Setting up Auto Polling, 73
Setting up Multi-User, 28
Setting up PayClock, 34
Setting up your Terminal, 66
Settings Tab - FaceIN, 68
Setup an administrator-FaceIN, 11
Setup Tab, 30, 37
Setup the network communications-FaceIN, 10
Setup the Pay Period, 34
Shift, 36
Software Installation, vii
Software Troubleshooting, 76
System Requirements, 7

T

- Telephone Support, 6
- Terminal Installation, v
- Terminal Manager Tab, 30
- Terminal Startup, vi
- Terminals Tab, 44
- Timecard Color Legend, 49
- Timecard Ribbon Bar, 45
- Timecard Timeline, 51
- Timecard Toolbar, 48
- Timecards Tab**, 30
- Troubleshooting, 4

U

- Update/Poll Schedule Tab - FaceIN, 69
- Updating the FaceIN, 71
- Upgrades, 3
- Using PayClock, 31
- Using the FaceIN, 20
- Using the List tab of the timecard table, 58
- Using the PayClock Software, 29
- Using the Quick Search, 47
- Using the Ribbon Bar, 29

V

- Verification Method Recommendations, 16
- Viewing photos of employees punching, 59

One-Year Limited Warranty

Lathem warrants the hardware products described in this guide against defects in material and workmanship for a period of one year from date of original purchase from Lathem or from an authorized Lathem reseller. The conditions of this warranty and the extent of the responsibility of Lathem Time Corporation ("Lathem") under this warranty are listed below.

1. This warranty will become void when service performed by anyone other than an approved Lathem warranty service dealer results in damage to the product.
2. This warranty does not apply to any product which has been subject to abuse, neglect, or accident, or which has had the serial number altered or removed, or which has been connected, installed, adjusted, or repaired other than in accordance with instructions furnished by Lathem.
3. This warranty does not cover dealer labor cost for removing and reinstalling the machine for repair, or any expendable parts that are readily replaced due to normal use.
4. The sole responsibility of Lathem under this warranty shall be limited to repair of this product, or replacement thereof, at the sole discretion of Lathem.
5. If it becomes necessary to send the product or any defective part to Lathem or any authorized service dealer, the product must be shipped in its original carton or equivalent, fully insured with shipping charges prepaid. Lathem will not assume any responsibility for any loss or damage incurred in shipping.
6. **WARRANTY DISCLAIMER AND LIMITATION OF LIABILITY:** Except only the limited express warranty set forth above, the products are sold with no expressed or implied warranties of any kind, and the implied warranties of merchantability and fitness for a particular purpose are hereby expressly disclaimed. No warranties are given with respect to products purchased other than from Lathem or an authorized Lathem reseller and any such products are purchased "as is, with all faults." In no event will Lathem be liable for any direct, indirect, special, incidental or consequential damages arising out of or in connection with the delivery, use or inability to use, or performance of this product. In the event any limited remedy given herein shall be deemed to have failed of its essential purpose, Lathem's maximum liability shall be to refund the purchase price upon return of the product.
7. Proof of date of purchase from Lathem or an authorized Lathem reseller is required for warranty service on this product.
8. This Warranty grants specific legal rights. Additional legal rights, which may vary by locale, may also apply.
9. Should any difficulties arise with the performance of this product during warranty, or with any Lathem authorized service centers, contact Lathem Time at the address below:

Lathem Time Corporation
200 Selig Drive, SW
Atlanta, Georgia USA 30336
(800) 241-4990
(404) 691-0400
www.lathem.com

Copyright © 2011 Lathem Time Corporation. All rights reserved.