



LATHEM

# PayClock<sup>®</sup>

## Time & Attendance System



## User's Guide

For PC60 Systems

[www.lathem.com](http://www.lathem.com)

**THIS EQUIPMENT COMPLIES WITH FCC REQUIREMENTS  
PURSUANT OF PART-15**

**This device complies with Part 15 of the FCC Rules. Operation is subject to the following two conditions: (1) this device may not cause harmful interference, and (2) this device must accept any interference received, including interference that may cause undesired operation.**

**WARNING:** Changes or modifications to this product not expressly approved by the party responsible for compliance could void the user's authority to operate this equipment.

**NOTE:** This equipment has been tested and found to comply with the limits, pursuant to Part 15 of the FCC Rules. These limits are designed to provide reasonable protection against harmful interference in a business installation. This equipment generates, uses, and can radiate radio frequency energy and, if not installed and used in accordance with the instructions, may cause harmful interference to radio communications. However, there is no guarantee that interference will not occur in a particular installation. If this equipment does cause harmful interference to radio or television reception, which can be determined by turning the equipment off and on, the user is encouraged to try to correct the interference by one or more of the following measures:

- Reorient or relocate the receiving antenna.
- Increase the separation between the equipment and receiver.
- Connect the equipment into an outlet on a circuit different from that to which the receiver is connected.
- Consult the dealer or an experienced radio TV technician for help.

**This Class A digital apparatus complies with Canadian ICES-003.**

**Cet appareil numérique de la classe A est conforme a la norme NMB-003 du Canada.**



**Lathem Time Corporation**  
200 Selig Drive, SW  
Atlanta, Georgia USA 30336  
**(800) 241-4990**  
(404) 691-0400  
[www.lathem.com](http://www.lathem.com)

Copyright © 2013 Lathem Time Corporation. All rights reserved.

Revised 6-24-2013 Document Number: USG0095C

# CONTENTS

|   |           |
|---|-----------|
| <b>QUICK START STEPS .....</b>  | <b>IV</b> |
| <b>PACKAGE CONTENTS.....</b>  | <b>5</b>  |
| <b>SYSTEM REQUIREMENTS .....</b>  | <b>6</b>  |
| <b>INSTALL THE PAYCLOCK SOFTWARE.....</b>                                     | <b>7</b>  |
| <b>INSTALL THE USB TERMINAL MANAGER SOFTWARE .....</b>                        | <b>9</b>  |
| <b>SETTING UP A MULTI-USER SYSTEM.....</b>                                    | <b>15</b> |
| <b>ENABLE THE MULTI-USER FEATURE.....</b>                                     | <b>15</b> |
| <b>OPTIONAL USB TERMINAL ONLY INSTALLATION.....</b>                           | <b>16</b> |
| <b>MOUNTING THE PC60.....</b>   | <b>20</b> |
| <b>USING THE PC60.....</b>  | <b>23</b> |
| <b>USING THE PAYCLOCK SOFTWARE.....</b>                                       | <b>24</b> |
| <b>SETTING UP YOUR TERMINAL.....</b>  | <b>58</b> |
| <b>HARDWARE TROUBLESHOOTING .....</b>   | <b>59</b> |
| <b>SOFTWARE TROUBLESHOOTING.....</b>  | <b>61</b> |
| <b>APPENDIX A - PAYCLOCK CLIENT INSTALLATION IN A MULTI-USER SYSTEM .....</b> | <b>62</b> |
| <b>APPENDIX B - INTEGRATING PAYCLOCK WITH QUICKBOOKS... </b>                  | <b>64</b> |
| <b>APPENDIX C - PAYCLOCK CLIENT SOFTWARE WAN INSTALLATION.....</b>            | <b>66</b> |

Copyright © 2013 Lathem Time Corporation. All rights reserved. Reproduction of this document in whole or in part is strictly prohibited. This document may contain typographical or copy errors. PayClock, Lathem, the Lathem logo, and all other Lathem product names mentioned in this document are registered trademarks of Lathem Time Corporation. All other products, brand names, or company names mentioned in this document are properties and trademarks or registered trademarks of their respective companies.

# Quick Start Steps

Carefully follow each step of these instructions for a trouble-free experience.

1



Verify the contents of your system. (For more detailed information turn to page 6.)

2



Verify your computer meets the Minimum System Requirements listed in this User Guide, turn to page 8.

3



Install the **PayClock Software**. (For more detailed instructions turn to page 9.)

## Important Notes

Make sure your screen saver is not showing before inserting the installation CD's.

Open and close the CD-ROM drawer if the CD is not recognized when inserted.

4



Install the **USB Terminal Manager Software**. (For more detailed instructions turn to page 11.)

**Note:** To install the USB terminal on a different computer:

First install the PayClock software on the computer where you will run PayClock.

Next install the USB Terminal Manager software on the computer where you will connect the USB terminal.

5

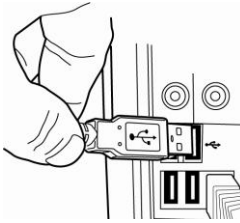

Connect the USB cable from the USB terminal to your computer when prompted to install the required software drivers. (For more detailed instructions turn to page 12.)

6



Open the PayClock software by clicking on the PayClock Icon. The default password is **lathem**. (For more detailed instructions turn to page 31.)

7

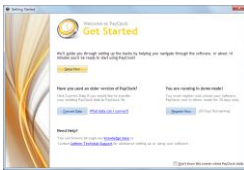

Click Setup Now from the Get Started window to configure PayClock. (For more detailed instructions turn to page 34.)

8

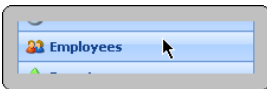

Add employees using the **Employees** button under the **Setup** tab.

To add a new employee, click **New** and then enter the employee data. (For more detailed instructions turn to page 39).

## PC60 & Finger Sensor or Remote Finger Sensor

9

You are now ready to enroll your employee's fingerprints. (For more detailed instructions turn to page 44).

## PC60

You are ready to start using your PayClock system..



# Welcome

## Purpose of this User's Guide

The purpose of this user's guide is not meant to be a complete manual for the product. It is a quick reference to get you started. Please refer to the PayClock Help for detailed product information, setup guidance, and operation information.

## Product Overview

Reliability, functionality and ease of use are trademarks of the PayClock software and terminals. The PayClock software and terminals are the ideal solution for businesses that want to track employee time and automate payroll.

Included in this package is the PayClock and USB Terminal Manager software, which you will use to manage data and the USB terminal.

### PayClock Proximity Terminal - PC60

The PayClock Proximity Time System is “real-time”. This means that when an employee punches In or Out the punch is added to the database at that time; no polling of the terminal is needed.

The PC50/PC60 utilizes a proximity badge system, meaning that employees will punch in and out by presenting a badge in front of the terminal's sensor. The PC50/PC60 also offers a backlit LCD screen to display important attendance information. Upon receiving a punch, the screen will display the employee's name, In/Out status, and total hours worked for the pay period. You may also elect to add custom text and audio messages to play for individual (or all) employees.

### IMPORTANT

The USB terminal (TS100, PC60, PC60with Finger Sensor or TSRFS) must be connected to the computer and the computer must be powered on for the unit to be operational. The USB Terminal will stop functioning if it is unplugged from the computer.

## Features and Specifications

- Simple proximity badge system to clock in and out.
- Instant identification eliminates buddy punching (PC60 with Wall Mount Finger Sensor or Remote Finger Sensor).
- Capable of playing audio and displaying text messages.
- Connects to the computer through a single plug-n-play USB cable, which also provides power to the unit.
- Real-time system requires no polling.
- Comprehensive support agreements minimize technical difficulties
- Numerous accessory options to enhance the functionality.

## Upgrades

If you find that you need to accommodate more employees in your system or if you would like enhanced software capabilities, consider purchasing a software upgrade for your system. A number of accessories are offered to further enhance your PayClock system.

- Increased employee capacity
- Customized export options
- Customized reporting options
- Multi-user capabilities

Upgrading is as easy as visiting <http://shop.lathem.com> or open PayClock and click on the PayClock orb in the upper left corner and select **Upgrade PayClock**. Then select the options you would like to purchase and download your software upgrade. Options are instantly activated upon receipt of online payment.



## Accessories

A number of accessories are offered to further enhance your PayClock system. Visit <http://shop.lathem.com> to purchase additional accessories like the ones listed below.

- Badges
- Badge Racks
- Fingerprint Sensor attachment
- Annual Support Agreements

## Getting Help

The purpose of this user's guide is not meant to be a complete manual for the product. It is a quick reference to get you started. Please refer to the PayClock Help for detailed product information, setup guidance, and operation information.

You can access the help desk and answers to your issues in a number of different ways. In addition to resources within the PayClock software, assistance may be accessed online, via email, via telephone, or through your dealer. Don't forget annual support contracts are also offered.

## PayClock Help

The PayClock Help allows you to search through an index of help topics to locate the answer you need. To launch the Help, click the Help button on the ribbon bar.

## Troubleshooting

For answers to Frequently Asked Questions, refer to the Troubleshooting sections of this User Guide on page 68 and 72.

## Online and Email Support

Lathem.com provides access to numerous support resources that will allow you maximize your use of PayClock. Help may be accessed by visiting the following link:

<http://support.lathem.com>

On the Support page, you may also submit a question through our online knowledgebase and one of our technicians will respond to your inquiry within 24 hours. Email support is free to all registered users.

### **Telephone Support**

The help desk is available between the hours of 8am and 7pm Monday through Friday. Please call **(800) 241-4990** to speak with our help desk. You will receive free technical support for the first 30 days after your initial call. After that period, you may purchase an Annual Support Agreement which will cover all calls for one year or you may pay a per-call fee.

### **Annual Support Agreements**

Annual support contracts are designed to keep your terminal and PayClock software working seamlessly. For a single annual fee, your Support Agreement offers the following advantages:

- Unlimited toll-free telephone support (versus a per-call fee) and priority status for calls
- Unlimited access to the extensive library of web-based tips and FAQs
- Free software updates and version upgrades during the Support Period, giving you free access to the most current software features
- Quick exchanges for damaged or broken terminal, thereby reducing downtime
- Extended parts and labor warranty helps you to save money on repairs needed after the regular product warranty has expired

To learn more about annual support contracts and to make a purchase, contact us at (800) 241-4990 or visit <http://www.lathem.com/support/support-plans.aspx>

# Package Contents

Please verify that your package includes ALL of the following items. If your package is missing an item, please call the help desk at 1-800-241-4990.

## PayClock Proximity Terminal - PC60

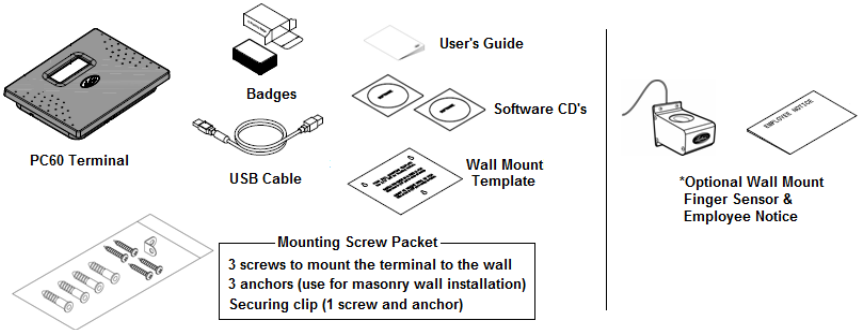

## Recommended Installation Tools (PayClock Proximity Terminal)

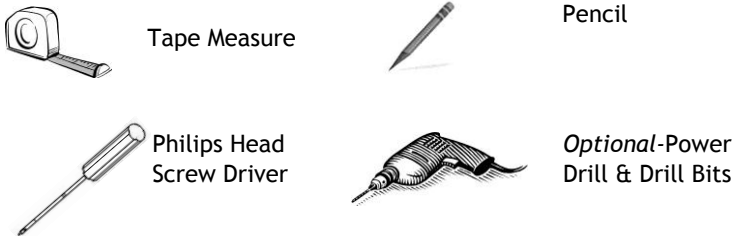

## System Requirements

You must verify that your system meets ALL of the minimum requirements listed below in order to run PayClock on your computer. Do not install the software if your system does not meet these minimum requirements!

### Requirements:

- **Processor:** 1 GHz or higher
- **Operating System:** Microsoft Windows 32-Bit or 64-Bit
  - XP - SP2 or later
  - Vista
  - Windows 7 or 8
  - Server 2003 or 2008 (Standard or Enterprise Edition)
- **Memory:** 1 GB of RAM or higher
- **Hard Disk Drive:** Up to 450 MB free disk space; up to 1 GB if the .NET framework is not installed
- **Display:** 1024x768 or higher resolution
- **CD-ROM Drive:** Required
- **Internet:** 56 Kbps (broadband recommended for online features/services)
- **Printer:** Any printer compatible with Windows XP SP2 or later
- **Network Interface:** Network adaptor configured for TCP/IP connected to a switch on LAN network.
- **Additional Software:**
  - Microsoft .Net 3.5 SP1 (included in the installer)
  - Internet Explorer 7.0 or later

## Install the PayClock Software

The PayClock install loads the client and server application as well as your database.

**CAUTION:** Before proceeding with your PayClock installation, verify that your PC meets ALL of the System Requirements listed on page 8!

### Standard Install

Follow these instructions for these scenarios whether it is a new install or an upgrade:

- You want PayClock to only run on one computer.
- or-
- You want to install the PayClock Server in multi-user system (The multi-user license must be activated if you wish to access the PayClock software from different computers on your network. Additional license fees may apply. You will have to register your PayClock software first in order to activate the multi-user license.)

### □ Run the PayClock Setup Program

- Go to the computer where you want to install PayClock.
- Make sure your screen saver is not showing before inserting the PayClock CD.

**XP | Vista | Windows 7 | Server 2003 | Server 2008**

- Insert the **PayClock CD** into your computer's CD-ROM drive. **Note:** Click Allow or Yes at the User Account Control confirmation window.
- The Setup program should run automatically. If not, follow the steps below.
  - Click **Start | My Computer** or **Computer**.
  - Double click on the drive that contains the PayClock installation CD.

## Windows 8

- Click the message “Tap to choose what happens on the disk.”.
- Select Run Setup.exe. **Note:** Click Yes at the User Account Control confirmation window.

### ❑ Follow the Setup Steps

- It may take the install a few minutes to start, please be patient.
- From the Install PayClock window click on **Next**.
- Read the License Agreement and select **I accept the terms of the license agreement** and **Next** to move forward.
- The Standard Install (Recommended) will be selected, click **Next** to continue.
- At the Ready to Install screen, click **Next**.
- At the Server Summary screen click the Print button, this data may be needed at a later time. Click **Next** to move forward.
- At the Installation Complete screen click **Finished**.

### ❑ Open PayClock

- After installing, you can run PayClock by clicking its icon. The default log in is Admin with the password ‘**lathem?**’.

### ❑ PayClock Product Registration

- From the Getting Started window, register PayClock via the Internet or phone. You must register within 30 days of installing the software. **Note:** You cannot activate the multi-user license until you register PayClock.

### ❑ Purchase Features

- Contact the help desk by calling 1-800-241-4990 or visit <http://shop.lathem.com> to purchase accessories and software modules.
- Options include employee capacity upgrades, multi-user, long-reach cables, additional badges, badge racks and more.

**Continue to the USB Terminal Manager installation**

## Install the USB Terminal Manager Software

The USB Terminal Manager install loads the client application and drivers for the selected USB terminal. Follow these instructions for this scenario:

### □ Run the USB Terminal Manager Setup Program

- Only run the USB Terminal Manager Setup program if you use a TS100, TS-RFS, PC60 or PC60 with TS-WFS terminal which communicates using a USB cable.
- Make sure your screen saver is not showing before inserting the CD.

#### XP | Vista | Windows 7 | Server 2003 | Server 2008

- Insert the **USB Terminal Manager CD** into your computer's CD-ROM drive. **Note:** Click Allow or Yes at the User Account Control confirmation window.
- The Setup program should run automatically. If not, follow the steps below.
  - Click **Start | My Computer** or **Computer**.
  - Double click on the drive that contains the PayClock USB Terminal Manager installation CD.

#### Windows 8

- Click the message "Tap to choose what happens on the disk."
- Select Run Setup.exe. **Note:** Click Yes at the User Account Control confirmation window.

## ❑ Follow the Setup Steps

- It may take the install a few minutes to start, please be patient.
- From the USB Terminal Manager installation window click on **Next**.
- At the Choose Terminal selection window, select the USB terminal that will be connected to the computer and then click **Next** to move forward.
- At the Ready to Install screen, click **Next**.

## ❑ Device Driver Installation - Windows XP

- This window will display 2 times with the options “Continue Anyway” or “Stop Installation”, be sure to select **Continue Anyway**. **Note:** The device drivers for the terminal will not be installed if you select Stop Installation.

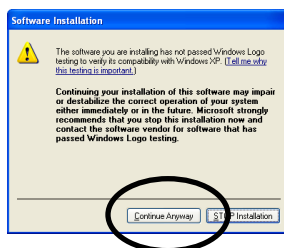

## ❑ Connect the PayClock USB terminal to the Computer

- Connect the USB cable coming from the PayClock USB terminal to an available USB port on your computer when prompted. See example below.

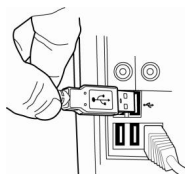

- **Do not click Next**, wait for the drivers to be loaded automatically.



- The computer will automatically begin installation of the required software drivers. Follow these instructions to successfully complete the installation of the software drivers.

## ❑ Windows XP - Install the USB Drivers

These two software drivers must be installed for the PayClock USB terminal to operate properly: TUSB2136 Firmware Loader and Lathem TouchStation LCD/LED USB Device.

### NOTE about USB terminals using a Finger Sensor

A third driver (U.areU. 4000B) will load automatically if the PayClock USB terminal has a fingerprint reader.

Two separate “Found New Hardware Wizards” will appear in succession. **You must complete both Wizards.** Please note that it may take up to one minute for each Wizard to automatically appear. Please be patient.

- After successfully connecting the PayClock USB terminal to your computer the message, “**Found New Hardware**” will show in the Notification Area with the USB icon .
- The “**Found New Hardware Wizard**” will display. Select “**No, not this time**” and click “**Next >**”.



**Note:**  
Up to 1 minute may pass before the message displays, please be patient.

- Select “Install the software automatically (Recommended)” and click “Next >”.

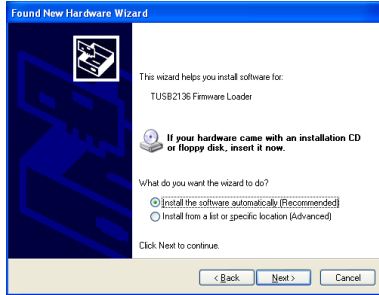

- When the driver is located, this message will display. Click “Continue Anyway”.

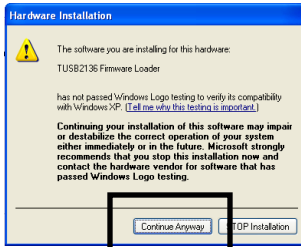

**Important:**  
Do NOT select “STOP Installation” or your terminal will not operate!

- Click Finish to complete the process of loading the first driver.
- Another “Found New Hardware Wizard” will display. Select “No, not this time” and click “Next >”.



**Note:**  
Up to 1 minute may pass before the message displays, please be patient.

- Select “Install the software automatically (Recommended)” and click “Next >”.



- When the driver is located, this message will display. Click “Continue Anyway”.

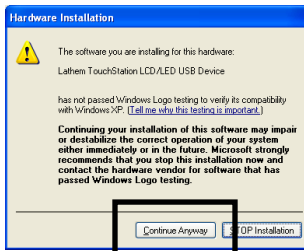

**Important:**  
Do NOT select “STOP Installation” or your terminal will not operate!

- Click Finish to complete the process of loading the second driver.
- Following the completion of installing the drivers, the PayClock USB terminal should light up, displaying the current time and date.

## ❑ Windows Vista, Windows 7 or Windows 8 USB Drivers

Please note that it may take up to one minute or more for the drivers to be automatically installed. Please be patient.

- After successfully connecting the PayClock USB terminal to your computer the message, “Found New Hardware” will display.
- After the drivers are automatically installed, a message will display notifying you the drivers have successfully installed.

## **❑ Complete the Installation**

- The Installation Complete window will display after the drivers are loaded, click Finished to complete the installation and reboot the computer if prompted.
- The USB Terminal Manager icon will display in the notification Area with Device Connected.

## Setting up a Multi-User System

PayClock is by default a single user system. You must purchase and enable the multi-user feature in order to access PayClock from other computers on your network.

**Note:** You must register your PayClock software before enabling the Multi-User feature even if you have already paid for the feature. After registering PayClock, call the help desk for a feature un-lock code.

### What is the difference between a Single User and Multi-User system?

With a single user system users cannot access the PayClock from different computers on the network. With a multi-user system other users can have the PayClock client installed on their computers and access PayClock across the network.

#### Enable the Multi-User Feature

- Open the PayClock software.
- Click on the PayClock orb in the upper left hand corner and select **Upgrade PayClock**.
- The Feature Wizard will open, click **Next**.
- At Number of Users select **Multi-user**.
- Click **Next** if you wish to demo the feature, click **Finish**. This will activate the feature for a 30 day trial.
- If you wish to purchase the feature select **Purchase the selected feature** and click **Next**.
- Enter your credit card information and click **Process Payment**.
- Your system will now be a multi-user system; you can install the PayClock client on other computers and access PayClock across the network.

**See the PayClock Help for detailed information on setting up additional PayClock users.**

## Optional USB Terminal only Installation

These instructions identify how to install a USB terminal on a separate computer from the one which contains the PayClock software.

**Note:** The second computer **MUST** be on the same Local Area Network (LAN) as the PayClock software installation.

### ❑ Run the USB Terminal Manager Setup Program

- Make sure your screen saver is not showing before inserting the CD.

|   |
|---|
| <b>XP   Vista   Windows 7   Server 2003   Server 2008</b> |
|---|

- Insert the **USB Terminal Manager CD** into your computer's CD-ROM drive. **Note:** Click Allow or Yes at the User Account Control confirmation window.
- The Setup program should run automatically. If not, follow the steps below.
  - Click **Start | My Computer** or **Computer**.
  - Double click on the drive that contains the PayClock USB Terminal Manager installation CD.

|                  |
|------------------|
| <b>Windows 8</b> |
|------------------|

- Click the message "Tap to choose what happens on the disk."
- Select Run Setup.exe. **Note:** Click Yes at the User Account Control confirmation window.

### ❑ Follow the Setup Steps

- It may take the install a few minutes to start, please be patient.
- From the USB Terminal Manager installation window click on **Next**.

- At the Choose Terminal selection window, select the USB terminal that will be connected to the computer and then click **Next** to move forward.
- At the Ready to Install screen, click **Next**.

### ❑ **Device Driver Installation - Windows XP**

- This window will display 2 times with the options “Continue Anyway” or “Stop Installation”, be sure to select **Continue Anyway**. **Note:** The device drivers for the terminal will not be installed if you select Stop Installation.

### ❑ **Connect the PayClock USB terminal to the Computer**

- Connect the USB cable coming from the PayClock USB terminal to an available USB port on your computer when prompted.
- **Do not click Next**, wait for the drivers to be loaded automatically.
- The computer will automatically begin installation of the required software drivers. Follow these instructions to successfully complete the installation of the software drivers.

### ❑ **Windows XP - Install the USB Drivers**

These two software drivers must be installed for the PayClock USB terminal to operate properly: TUSB2136 Firmware Loader and Lathem TouchStation LCD/LED USB Device.

#### **NOTE about USB terminals using a Finger Sensor**

A third driver (U.are.U. 4000B) will load automatically if the PayClock USB terminal has a fingerprint reader.

Two separate “Found New Hardware Wizards” will appear in succession. **You must complete both Wizards**. Please note that it may take up to one minute for each Wizard to automatically appear. Please be patient.

- After successfully connecting the PayClock USB terminal to your computer the message, “**Found New Hardware**” will show in the Notification Area with the USB icon .
- The “**Found New Hardware Wizard**” will display. Select “**No, not this time**” and click “**Next >**”.
- Select “**Install the software automatically (Recommended)**” and click “**Next >**”.
- When the driver is located, this message will display. Click “**Continue Anyway**”.

Click Finish to complete the process of loading the first driver.

- Another “**Found New Hardware Wizard**” will display. Select “**No, not this time**” and click “**Next >**”.
- Select “**Install the software automatically (Recommended)**” and click “**Next >**”.
- When the driver is located, this message will display. Click “**Continue Anyway**”.
- Click Finish to complete the process of loading the second driver.
- Following the completion of installing the drivers, the PayClock USB terminal should light up, displaying the current time and date.

## □ Windows Vista, Windows 7 or Windows 8 USB Drivers

Please note that it may take up to one minute or more for the drivers to be automatically installed. Please be patient.

- After successfully connecting the PayClock USB terminal to your computer the message, “**Found New Hardware**” will display.
- After the drivers are automatically installed, a message will display notifying you the drivers have successfully installed.



## **❑ Complete the Installation**

- The Installation Complete window will display after the drivers are loaded, click Finished to complete the installation and reboot the computer if prompted.
- The USB Terminal Manager icon will display in the notification Area with Device Connected.

## Mount the USB Terminal

Select a site to place the USB terminal that will be convenient to employees clocking in and out. If you wish to increase the distance between the USB terminal and the computer's USB port, you may utilize the following USB cable extenders available from the help desk at (800) 241-4990 or from <http://shop.lathem.com>.

- 16 foot USB Active Extension Cable (P/N: USBCABLE16)  
Connect up to four cables in succession.
- USB Super Extender (P/N: USBEXTENDER)  
Extend distance up to 150' using Cat5 cable sold separately.

## Mounting the PC60

**Step 1:** Select a site to install your PC60 terminal that will be convenient to employees clocking in and out. The included USB cable is 15 feet long.

The PC60 terminal derives its power from the USB Port of its host computer. No other power source is required for basic operation.

**Step 2:** After selecting the appropriate installation site, use masking tape to hold the included Mounting Template onto the wall. Drill holes using the template as a guide. Note: the bottom of the terminal should be about **45 inches** from the floor.

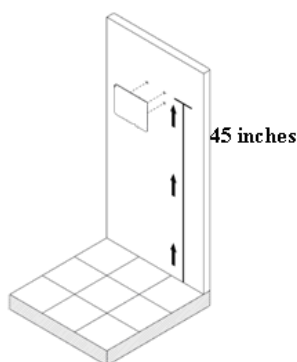

Remove the Template from the wall and install the included mounting screws. Install the three larger screws, leaving approximately  $3/16$  inch of the screws exposed. **Do not tighten all the way.** Retain the smaller screw for later.

**Note:** For sheetrock walls, drill a  $3/16$ " diameter hole through each of the four screw locations; each approximately  $1-1/2$ " deep. Install the plastic "anchors" included in the mounting screw packet.

**Step 3:** Insert the small "L"-shaped security bracket into the slot at the bottom-rear of the PC60, so that the tab with the hole points downward, away from the keyhole slot that can be seen immediately above.

Hang the terminal on the wall, aligning the three keyholes on the rear of the enclosure with the three protruding screw heads, and then pressing downward on the terminal housing until it lowers onto the screws.

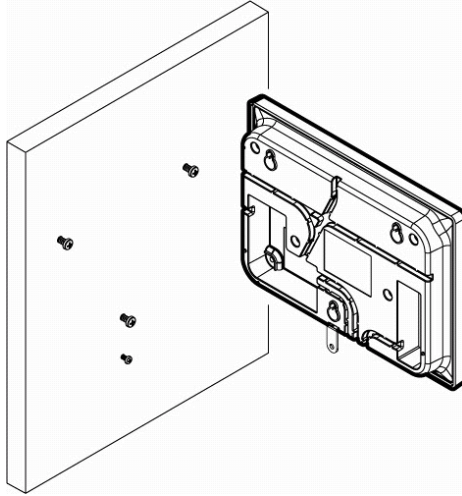

Screw the small screw into the hole of the tab from the small “L”-shaped bracket at the bottom of the enclosure. This will fasten the PC60 to the wall and keep it from being easily removed.

## Using the USB Terminals

### Using the PC60

To punch, move the badge towards and below the illuminated oval target area on the front of the PC60. When the badge is in close proximity to the PC60, a confirmation beep will sound, a text message will appear, a custom audio message may be played, and the oval target area will turn either green or red indicating a good or bad transaction.

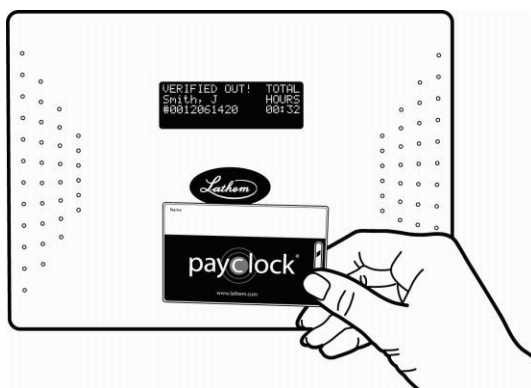

If you scan a badge that has not yet been assigned to a specific employee in PayClock, the terminal will display an error message.

**NOTICE:** The PC60 utilizes an internal antenna to read the employee badges. Make sure these badges are stored at least 6” away from the PC60 when not in use to avoid accidental badge reads.

## Using the PayClock Software

PayClock utilizes a sleek user interface that allows you to get more out of the functions you use most. The interface provides centralized navigation to all parts and functions within the software. Navigation panes allow you to quickly manage payroll rules, employees, payroll data and reports. Simply click on a tab or button to open the pane and associated window. Use the “Quick Action” buttons under Payroll Process or Other Tasks to access routine operations.

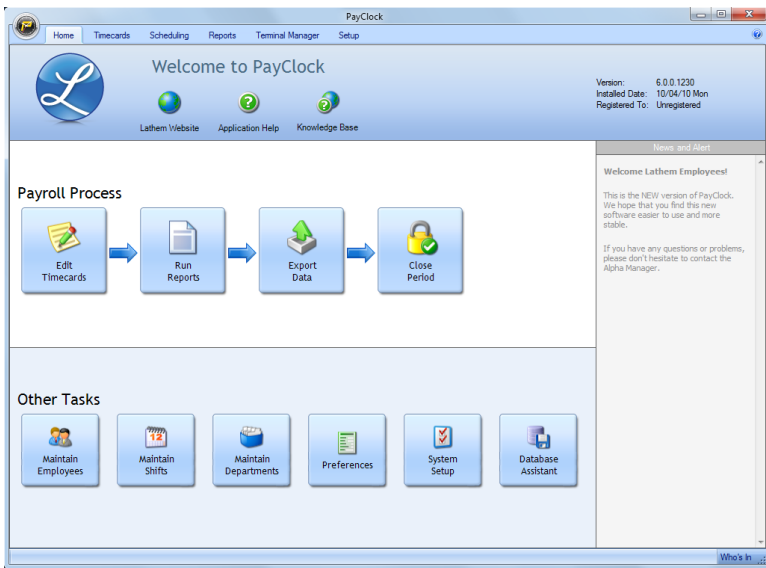

## Using the Ribbon Bar

The PayClock **Ribbon Bar** has replaced the typical menus and toolbars. This new bar allows PayClock to present the functions you need on a set of organized tabs. The tabs are; Home, Timecards, Scheduling, Reports, Terminal Manager and Setup. This new ribbon bar makes using PayClock easier. Because of the way that the tabs are organized, you get to the functions quicker.

- **Home Tab:** The Home tab contains information on how to start using PayClock along with quick action buttons in a flow chart of the routine process of use.
- **Timecards Tab:** The Timecards tab contains functions for polling your terminal(s), editing employee timecards, globally editing a group of employees, exporting data for payroll and closing the pay period.
- **Scheduling Tab:** The Scheduling tab presents a summary or snapshot of the estimated labor coverage in hours and dollars in a calendar view. In addition the Scheduling tab is used to apply shifts to groups of employees, allowing shift assignments in mass rather than having to assign shifts to employees individually.
- **Reports Tab:** The Reports tab allows you to run reports on information that is stored in the PayClock database.
- **Terminal Manager Tab:** The Terminal Manager tab allows you to set up terminals and assign your employees to the terminals. You can also update and poll the terminals from this tab.
- **Setup Tab:** The Setup tab contains functions for configuring your company information, pay period rules, departments, employees, shifts, payroll exports, PayClock users and preferences.

## The PayClock Orb

The **PayClock Orb**, located at the top left corner, allows quick access to a number of important tools. Click on the PayClock orb to access the following critical functions:

- Backup/Restore Data
- Upgrade PayClock
- Check for Updates
- Support Assistant
- Exit

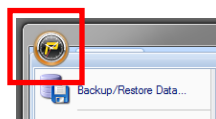

## Logging into PayClock

PayClock is a single user system by default with one user account, Administrator. The Administrator account gives the user full access to PayClock.

Open the PayClock software by clicking on the  PayClock Icon located on your desktop.

### Log In

To begin using PayClock, you must first Log In to the system at the **Log In** window. PayClock has one default user; the **Administrator**. The Administrator has full access to system, information, and functions.

#### NOTE

You may upgrade PayClock to a “Multi-User” system. Refer to page 17 of this User’s Guide for information on upgrading to multi-user.

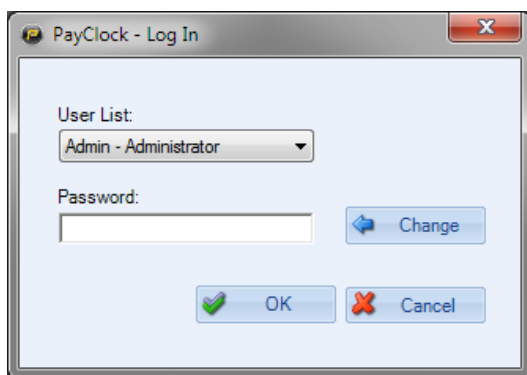

1. From the Log In window, choose **Administrator** from the **User List**.
2. Enter the default password: “**lathem**”.



3. Click **OK** and the software will open. A welcome tone will let you know that PayClock is ready for use.

## Create and Change Your Password

You should create your own unique password to protect sensitive payroll data.

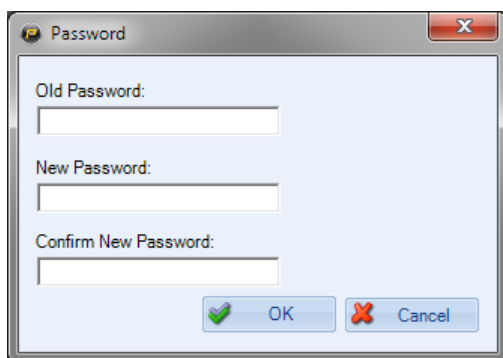

1. At the Log In screen, click the **Change** button.
2. Type in your **Old Password** (remember, the default is “lathem”).
3. Type in your **New Password** (the one you would like to create).
4. **Confirm** your new password by typing it in.
5. Click **OK** to finalize the change.

### NOTE

Passwords **are** case sensitive and may be up to 11 characters

## Register Your PayClock System

You may register your system anytime within 30 days of installing the software. If after 30 days you haven't registered your system you will be required to do so before continuing to use the software.

There are three ways to register your software:

- Complete the **Registration Wizard** by clicking the Register Now button on the Get Started window that appears upon log-in. Fill in the requested information and submit. If you do not have an internet connection, select **Print** at the end of the wizard to print and fax your information to the help desk at **1-800-252-2208**.
- Call the help desk at **1-800-241-4990** and select option number 1 from the telephone menu to speak with a representative.
- Visit **<http://www.lathem.com/contact-us/register-your-product.aspx>** and follow the steps outlined.

## Setting up PayClock

### How does PayClock calculate time?

PayClock uses an open shift to define the start of the workday. An employee's open shift starts with his/her first punch of the day and continues until the day change or for 14 hours if working past the day change. The work day length is set to 14 hours by default.

Example 1:

- Jane Doe's first punch Monday morning was at 7:30 am.
- She didn't punch out to leave for the day until 10:00 pm. PayClock calculated her time as 14 hours and 30 minutes because she didn't work past the day change.

Example 2:

- Jane Doe's first punch on Tuesday was at 1:00 pm.
- Using the maximum work day length setting of 14 hours, PayClock defines the expected end of her open shift to be by 3:00 am on Wednesday.
- Jane's time will calculate and no missing registration exception will be generated if she punches out to complete her shift by 3:00 am on Wednesday.
- Jane's time will not calculate and a missing registration exception will be generated if she punches out to complete her shift after 3:00 am on Wednesday.

### Minimum PayClock Set up

After completing the hardware and software installation, you should set up your basic company structure. This includes the pay period, overtime and rounding.

From the Getting Started window click the Setup Now button or click the Setup tab on the ribbon bar.

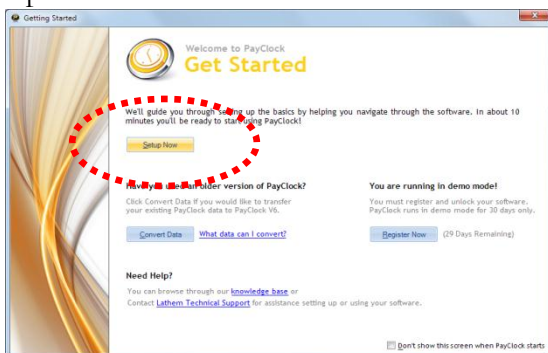

Use the buttons on the Setup tab to set up your basic company structure.

## Pay Period Setup

- At the Setup tab, click the Pay Class button.
- Select the Standard pay class item from the List box on the left side of the window. The Standard pay class will open on the General tab.
- Select the Pay Period Type. The available options are Weekly, Bi-Weekly, Semi-Monthly, Monthly and Custom.
- Set when the pay period starts under the Current Pay Period date field.

**Click the Help button is you need assistance setting up the pay period.**

- Click Save to keep your changes.

## Overtime Setup

- With the Standard pay class item still selected, click on the Overtime tab.
- To set up daily overtime, select the pay code and set the limit.

- To set up weekly overtime, select the pay code and set the limit.

**Click the Help button is you need assistance setting up the overtime.**

- Click Save to keep your changes.

### Rounding Setup

- With the Standard pay class item still selected, click on the Advanced tab.
- Select the rounding option. **Note:** The “Not Selected” option will set the rounding to true time or minute to minute.

**Click the Help button is you need assistance setting up the rounding.**

- Click Save to keep your changes.

### Shift Length Setup

The Maximum Work Day Length setting allows you to enter how long employees would normally work in one day. **Note:** Normally, you should leave this field at the default setting of 14 hours. If the setting too large you may see punches from different days linked together.

- With the Standard pay class item still selected, click on the Advanced tab.
- Enter the amount of time expected to be worked for a day in the Maximum Work Day Length field.. **Note:** It is recommended to leave the setting at the default 14 hours.

**Click the Help button is you need assistance setting up the maximum work day length.**

- Click Save to keep your changes.

## Additional Software Setup

The Setup tab of the ribbon bar is used to configure the PayClock software for your company, pay period rules, departments, employees, shifts, payroll exports, PayClock users and preferences.

See the [PayClock Help](#) for detailed information on the Setup tab.

### Company Button

At the Company button of the Setup tab you define your basic company information.

### Pay Class Button

The Pay Class button of the Setup tab on the ribbon bar allows you set up and maintain your company's pay policies for handling payroll. You can configure the pay policies your company uses, such as your pay period, overtime, break and other advanced pay class features. The Pay Class set up consists of four tabs; General, Overtime, Break and Advanced.

### Pay Codes Button

Pay Codes are accumulators or categories that collect either time or dollar amounts. You can change the pay rates or set the non-work hours to count toward overtime.

### Departments Button

At the Departments button of the Setup tab you define the departments used by your company. Departments can be used to track time by groups of employees. Additionally you can use departments to filter lists of employees. Also, if your terminal supports employee transfers, you can create departments so employees can transfer from one department to another department. PayClock allows you to set up to 100 departments.

### Breaks Button

At the Breaks button of the Setup tab you define the break and meal rules that will be applied to shifts. Breaks can be punched,

automatically deducted, or a combination of both. They can also be unpaid or paid. Breaks are applied to shifts. For example, you have a shift that starts at 7:30am and ends at 4:00pm with a 30 minute punched unpaid break that can be taken between 11:30am and 2:00pm. After defining the breaks assign them to shifts.

## **Shifts Button**

At the Shifts button of the Setup tab you define the work day for employees. Shifts identify when an employee is expected to punch In or Out and how to calculate the punches. For each shift rule you can define the start and end of the shift as well as the break associated with the shift. For example, you have a shift that starts at 7:30am and ends at 4:00pm with a 30 minute punched break. After defining the shift rules you can then assign shifts to the employees.

## **Employees Button**

The Employees button of the Setup tab on the ribbon bar allows you set up and maintain your employees in the software. You can enter their name, address, pay rate, emergency info, assign their benefit time, etc.

## **Exports Button**

At the Exports button of the Setup tab you define how PayClock will export data to your payroll service. See Appendix B - Integrating PayClock with QuickBooks for details on working with QuickBooks.

## **Users Button**

The Users button allows you to manage the user accounts for the PayClock software. You can add, edit and delete users and set or change the user passwords. When you click the Users button a list of the users will display.

## **Preferences Button**

The Preferences button allows you to choose how dates and times display in the software; you also define certain software settings.

## Add Employees and Assign Badges

The **Employees** button under the **Setup** tab is used to maintain the employees in the PayClock software. This will include adding, editing and terminating employees.

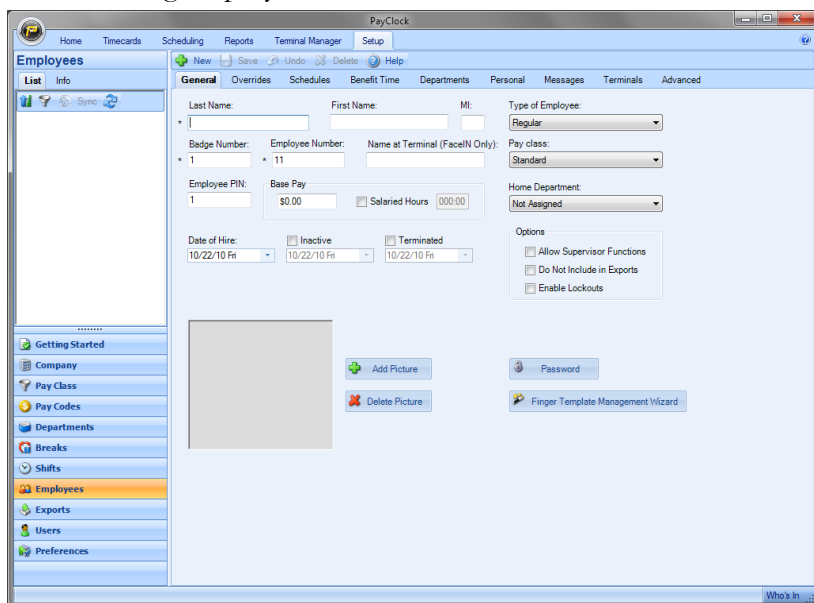

The **Employees** button has nine tabs - General, Overrides, Schedules, Benefit Time, Departments, Personal, Messages, Terminals and Advanced.

**General Tab** - Set up employee's name, badge and PIN.

**Overrides Tab** - Override global break settings for an employee.

**Schedules Tab** - Assign shifts to an employee.

**Benefit Time Tab** - Track benefit time for an employee.

**Departments Tab** - Assign optional departments to an employee.

**Personal Tab** - Set up employee addresses and contact information.

**Messages Tab** - Assign messages to display at the terminal.

**Terminals Tab** - Maintain employee assignments to terminals.

**Advanced Tab** - Override the maximum work day length and maximum hours out rule for an individual employee.



## Add New Employees

### General Tab

After adding the employees click on the Terminal Manager tab and update your terminal(s).

1. From the Ribbon Bar, click the Setup tab and click on the Employees button. The Employees window will display.
2. Click the New button, the next available blank employee template will display.
3. Type in the employee's last name, first name and middle initial.
4. In the Badge Number field enter the badge number to use for punching in and out at the PC60terminal. Each badge contains a unique ten digit badge number on the back (see example below). **The number of the badge assigned to an employee must match the number entered in the Badge Number field in that employee's profile.**

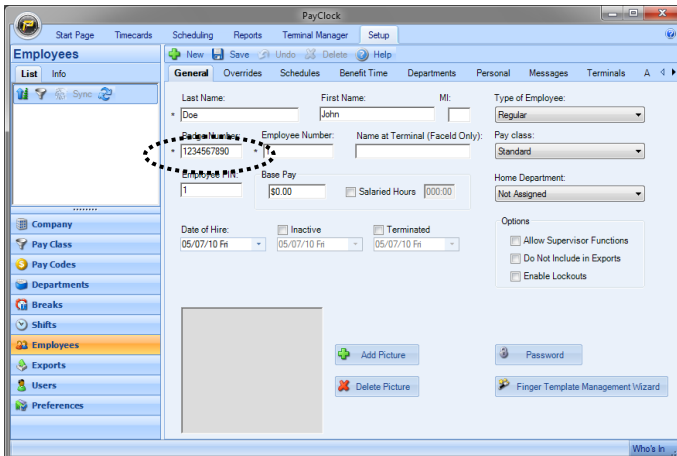

5. If your company uses an Employee Number, enter it here. Usually, payroll services require an employee number for exports.
6. PayClock automatically fills in the Employee PIN but you can change it if you like. To change the PIN, enter the number in the Employee PIN field. **Note:** The Employee PIN is not supported with the USB terminals.
7. Enter the employee's hourly wage under Hourly Base Pay.
8. If the employee is salaried select the Salaried Hours option and enter how many hours the employee is expected to work during the pay period.  
**Note 1:** Reports will use the hours you have entered in this field. Any punches will be ignored in reporting.  
**Note 2:** Employees with the Salaried option selected can not be exported. The Do Not Include in Exports option will be checked and will be dimmed.
9. From the list under Type of Employee choose whether this person is Regular, Temporary, Seasonal or Contract.
10. At Pay Class select the pay class to use for the employee. This setting determines which pay period and overtime rules will be applied.
11. At Home Department, select the employee's home department.
12. Check the Allow Supervisor Functions box if this employee can perform supervisor functions at the terminal, such as adding or deleting punches.
13. At Do Not Include in Exports check this box if you do not want to include this employee in the file you export for payroll.
14. Check the Enable Lockouts option if you want to restrict employees from punching In too early or Out too late.
15. Enter the employee's hire date under Date of Hire.
16. Click Save to keep your changes.

The next section covers each topic briefly to give you an overview of the system. See the PayClock Help for detailed information on each topic.

### Overrides Tab

You use the Overrides tab to define punched or automatically deducted breaks for individual employees on the open shift. Any defined breaks on this tab will override the global break set up on the Pay Class | Break tab.

### Schedules Tab

The Schedules tab is used to apply shifts to individual employees. The shifts applied to the employee will make up the employees work schedule. You can define the employees work schedule in the calendar and assign shifts by date. The employee's schedule displays in a calendar view showing the shift details assigned to each date. A labor coverage chart is also available which verifies that there is enough labor coverage but not too much for a work day.

| Employee Schedule  | Sunday   | Monday   | Tuesday   | Wednesday                                      | Thursday  | Friday   | Saturday                            |
|--|--|--|---|--|---|--|-------------------------------------|
| OFF  |  |  | 6:30am-3:00pm<br>Hours: 8:00<br>Wages: \$90.00                  | 6:30am-3:00pm<br>Hours: 8:00<br>Wages: \$80.00 | 6:30am-3:00pm<br>Hours: 8:00<br>Wages: \$80.00          | 6:30am-3:00pm<br>Hours: 8:00<br>Wages: \$90.00 | OFF<br>Hours: 8:00<br>Wages: \$0.00 |
| Flexible Shift<br>7:00am-4:00pm<br>6:00am-4:30pm<br>6:00am-3:00pm<br>7:25am-4:00pm<br>Late Shift |  |  |   |  |   |  |                                     |
| OFF  | 6:30am-3:00pm<br>Hours: 8:00<br>Wages: \$80.00 | 6:30am-3:00pm<br>Hours: 8:00<br>Wages: \$80.00 | 6:30am-3:00pm<br>Hours: 8:00<br>Wages: \$80.00                  | 6:30am-3:00pm<br>Hours: 8:00<br>Wages: \$80.00 | 6:30am-3:00pm<br>Hours: 8:00<br>Wages: \$90.00          | 6:30am-3:00pm<br>Hours: 8:00<br>Wages: \$90.00 | OFF<br>Hours: 8:00<br>Wages: \$0.00 |
| OFF  | 6:30am-3:00pm<br>Hours: 8:00<br>Wages: \$0.00  | 6:30am-3:00pm<br>Hours: 8:00<br>Wages: \$80.00 | 6:30am-3:00pm<br>Hours: 8:00<br>Wages: \$80.00                  | 7:30am-4:00pm<br>Hours: 8:00<br>Wages: \$80.00 | 6:30am-3:00pm<br>Hours: 8:00<br>Wages: \$80.00          | 6:30am-3:00pm<br>Hours: 8:00<br>Wages: \$80.00 | OFF<br>Hours: 8:00<br>Wages: \$0.00 |
| OFF  | 6:30am-3:00pm<br>Hours: 8:00<br>Wages: \$80.00 | 6:30am-3:00pm<br>Hours: 8:00<br>Wages: \$80.00 | One Day<br>09:00 AM - 05:00 PM<br>Hours: 8:00<br>Wages: \$80.00 | 6:30am-3:00pm<br>Hours: 8:00<br>Wages: \$80.00 | 6:30am-3:00pm<br>Hours: 8:00<br>Wages: \$80.00          | 6:30am-3:00pm<br>Hours: 8:00<br>Wages: \$90.00 | OFF<br>Hours: 8:00<br>Wages: \$0.00 |
| OFF  | 6:30am-3:00pm<br>Hours: 8:00<br>Wages: \$80.00 | 6:30am-3:00pm<br>Hours: 8:00<br>Wages: \$80.00 | 6:30am-3:00pm<br>Hours: 8:00<br>Wages: \$80.00                  | 6:30am-3:00pm<br>Hours: 8:00<br>Wages: \$80.00 | Oct 1<br>6:30am-3:00pm<br>Hours: 8:00<br>Wages: \$80.00 | 6:30am-3:00pm<br>Hours: 8:00<br>Wages: \$90.00 | OFF<br>Hours: 8:00<br>Wages: \$0.00 |

### **Benefit Time Tab**

You use the Benefit Time tab to track an employee's benefits, such as how much sick or vacation time they have or have taken. You can track up to 5 pay codes. The software keeps track of how much time the employee has taken and how much time the employee has left.

### **Departments Tab**

The Departments tab is used to assign employees to certain departments and also modify the pay rate when working in the department. When an employee transfers to one of these assigned departments their pay rate will reflect what was defined for that particular department.

### **Personal Tab**

You use the Personal tab to keep track of certain employee information, such as their address, phone number, custom field information and who to contact in an emergency.

### **Messages Tab**

You use the Messages tab to create messages and assign messages to display on the terminal for individual employees. These settings will override any messages defined at the terminal's properties Audio tab of the Terminal Manager tab.

### **Terminals Tab**

The Terminals tab is used to assign or remove an employee's assignment to the terminal(s) you have setup in your PayClock system.

### **Advanced Tab**

The Advanced tab is used to override the maximum work day length and maximum hours out rule for an employee. Either of these settings will override the Maximum Work Day or Maximum Hours Out to Start a New Shift setting on the Advanced tab of the Pay Class.

## Editing Timecards

The Timecards tab is used to manage employee punch data. You can view and edit employee punches as well as non-work time such as vacation time or dollar amounts such as tips. You can view employee data for open or closed pay periods. When you click on the Timecards tab you will see 4 areas, the Timecard Ribbon Bar, the Employee List, the Employee Timecard and the Timecard Timeline.

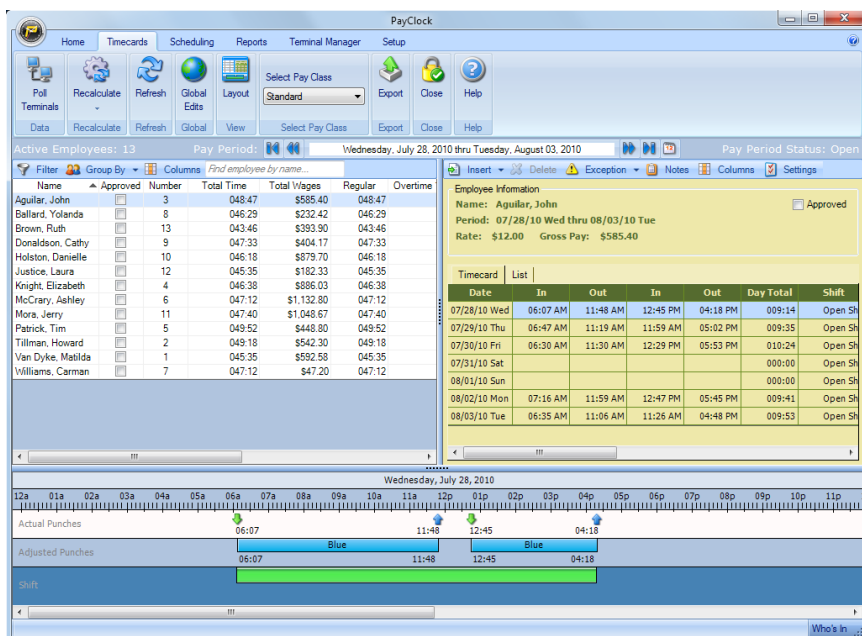

See the PayClock Help for detailed information on using the Timecard Tab.

## Timecard Ribbon Bar

The Timecard Ribbon Bar has the following button groups; Data, Recalculate, Refresh, Global, View, Select Pay Class, Export, Close and Help as well as a status bar. You can poll the terminal(s), recalculate employee data, make adjustments globally to groups of

employees, select which Pay Class to edit the data for, select the time period for the edits, export payroll data and clock the pay period.

## The Employee List and Toolbar

The Employee List displays employees along with their summary data such as wages, regular time, overtime, vacation, etc.

| Name                | Approved                 | Number | Total Time | Total Wages | Regular | Overtime 1 | Overtime 2 |
|---------------------|--------------------------|--------|------------|-------------|---------|------------|------------|
| Benedict, Frank     | <input type="checkbox"/> | 8      | 046:26     | \$522.37    | 046:26  |            |            |
| Cunningham, Barbara | <input type="checkbox"/> | 6      | 039:50     | \$597.50    | 039:50  |            |            |
| Heard, Doris        | <input type="checkbox"/> | 9      |            | \$0.00      |         |            |            |
| Jenkins, Nathan     | <input type="checkbox"/> | 3      | 054:02     | \$162.10    | 054:02  |            |            |

You can filter the employees that display in the list and define which columns display. You can also approve the employee timecards. Data can be viewed for open or closed pay periods.

When you highlight or select an employee in the list, the timecard on the right side of the window displays the data associated with the employee selected for the selected Pay Period. Use the Employee List to select an employee and the pay period navigation buttons to select the Pay Period.

The Employee List Toolbar allows you to filter and sort the list of employees as well as define the columns that display in the Employee List summary area.

You can also approve a timecard after finishing the edits. This will lock the employee's timecard and will not allow for any more edits. The approved option allows you to quickly see whose timecard edits have been finished and which employee(s) still need attention.

### Filtering the Employee List

Click the Filter  Filter button to choose which employees you want to appear in the employee list. When you click the Filter button the Filter Options window will open. You can choose All Employees or departments that you created. You can also include or exclude inactive or terminated employees.

- Department - From the list select the department or departments that hold the employees you want to display in the summary list.
- Show Terminated Employees - Check  this option if you want to display employees marked as terminated in the list. If you don't want terminated employees to display in the list, uncheck  the option.
- Show Inactive Employees - Check  this option if you want to display employees marked as inactive in the list. If you don't want inactive employees to display in the list, uncheck  the option.

### Using the Quick Search

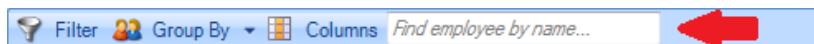

Type a few letters of the desired employees name in the Quick Search field; all employees with those letters will display in the employee list. The full name or just a few letters can be entered in the “Find employee by name...” field.

### Setting the Columns in the Employee List

Click the Columns  Columns button at the Employee List area to define the columns that will display in the Employee List. When you click the Columns button the Timecard Options window will open.

From the available columns, select what you want to display in the summary list by placing a check  in the box. If you don't want a column to display in the summary list uncheck  the box.

**Note:** The Name and Approved columns are fixed and can't be hidden or moved.

### Employee Timecard and Toolbar

The Employee Timecard is used to view and edit an employees punch and non-work data. Use the Employee List to select an

employee and the pay period navigation buttons to the select the pay period.

When an employee is selected from Employee List their individual timecard will display with their punch data for the selected pay period. The Timecard has 3 areas; the toolbar, the employee information and the timecard table.

The Timecard Toolbar allows you to add punches and non-work time, search for exceptions, insert notes and define the columns that display in the Timecard.

The Employee Information area displays the selected employee's name, the start and end of the selected pay period and the employee's hourly wage rate and gross pay. You can also Approve an employee's timecard. **Note:** The Employee Information area only displays when the timecard layout is set to "Side by Side".

The Timecard Table displays punch data and non-work time for the selected employee. You also use the table to edit data much like cells in a spreadsheet.

The screenshot shows the Payclock Timecard interface. At the top is a toolbar with buttons for Insert, Delete, Exception, Notes, Columns, and Settings. Below the toolbar is the Employee Information section, which displays the employee's name (Benedict, Frank), the selected pay period (08/16/10 Mon thru 08/22/10 Sun), and the hourly rate (\$11.25) and gross pay (\$0.00). There is an 'Approved' checkbox. Below the information is a table with two tabs: 'Timecard' and 'List'. The 'Timecard' tab is active, showing a table with columns for Date, In, Out, In, Out, Day Total, and Regular. The data rows show dates from 08/16/10 to 08/22/10 with corresponding punch times and totals. Arrows on the right side of the image point to the Timecard Toolbar, Employee Information, and Timecard Table.

| Date         | In | Out | In | Out | Day Total | Regular |
|--------------|----|-----|----|-----|-----------|---------|
| 08/16/10 Mon |    |     |    |     | 000:00    | 000:00  |
| 08/17/10 Tue |    |     |    |     | 000:00    | 000:00  |
| 08/18/10 Wed |    |     |    |     | 000:00    | 000:00  |
| 08/19/10 Thu |    |     |    |     | 000:00    | 000:00  |
| 08/20/10 Fri |    |     |    |     | 000:00    | 000:00  |
| 08/21/10 Sat |    |     |    |     | 000:00    | 000:00  |
| 08/22/10 Sun |    |     |    |     | 000:00    | 000:00  |

## Timecard and List Tabs

The Timecard Table has two tabs, Timecard and List.



- **Timecard tab** - This tab is used for the typical editing and viewing of punch data.
- **List tab** - This tab is designed specifically to be used to view the photos of employees who punch at the FaceIN terminal. This tab is not used with the USB terminals.

### Timecard Table Color Legend

The timecard table can display the rows or cells in colors that are used to identify certain conditions.

- **Light Blue** - A row that is light blue identifies that the row is selected.

|              |          |          |          |          |        |         |
|--------------|----------|----------|----------|----------|--------|---------|
| 08/18/10 Wed | 08:00 AM | 12:00 PM | 01:00 PM | 05:00 PM | 008:00 | 800-500 |
|--------------|----------|----------|----------|----------|--------|---------|

- **Light Red** - A light red cell identifies that there is an exception associated with the cell or the day. In this example the employee arrived late for their shift.

|              |          |          |          |          |        |         |
|--------------|----------|----------|----------|----------|--------|---------|
| 08/17/10 Tue | 08:05 AM | 12:00 PM | 01:00 PM | 05:00 PM | 007:55 | 800-500 |
|--------------|----------|----------|----------|----------|--------|---------|

- **Olive Green** - Cells that are colored light green identify that the day contains a department transfer. Cells that are light green are disabled and do not allow punches.

|              |          |          |  |  |        |         |
|--------------|----------|----------|--|--|--------|---------|
| 08/18/10 Wed | 08:00 AM | 09:00 AM |  |  | 001:01 | 800-500 |
| 08/18/10 Wed | 09:00 AM | 12:00 PM |  |  | 004:00 | 800-500 |
| 08/18/10 Wed | 01:00 PM | 05:00 PM |  |  | 008:00 | 800-500 |

### Setting the Columns in the Timecard Table

Click the Columns  Columns button at the Timecard toolbar to define the columns that will display in the timecard. When you click the Columns button the Timecard Options window will open. You can define the columns that display in the Employee List or the columns that display in the Timecard or other timecard settings.

From the available columns select what you want to display in the summary list by placing a check  in the box. If you don't want a column to display in the summary list uncheck  the box.

**Note:** The Date, In, Out, In and Out columns are fixed and can't be moved. The Date, In, Out, In, Out and Regular columns can't be disabled.

## Timecard Timeline

The Timecard Timeline is a snap-shot view of the shifts and punches for the selected date. The Timecard Timeline can be expanded, collapsed or hidden entirely. When the timeline is expanded it has 3 areas; the Actual Punches, the Adjusted Punches and the Shift.

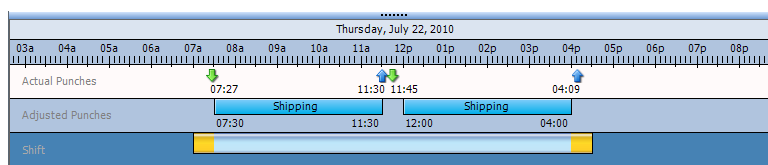

- **Actual Punches area** - Displays the unrounded punches.
- **Adjusted Punches area** - Displays the punches after they have been rounded.
- **Schedule area** - Displays the shift that is being used for the selected day.

The **open shift** will be represented by a green bar in the Schedule area.



An **assigned shift rule** will be represented by a light blue bar in the Schedule area. Note: In or Out revisions set up on the shift rule will be represented by a yellow area before (In revision) or after (Out revision) the light blue bar.



A **flexible shift rule** will be represented by a gray bar in the Schedule area.



## Hiding the Timeline

The Timecard Timeline can be expanded or collapsed by clicking on the expanding/collapsing bar. The bar is located between the timecard table and timeline. It is identified in the red circle below.

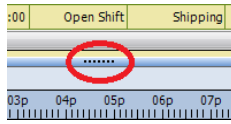

## Maintaining Employee Timecards

The Timecards tab is used to manage employee punch data. You can view and edit employee punches as well as non-work time such as vacation time or dollar amounts such as tips.

The timecard body contains an area that resembles a spreadsheet for keying in punch data. **Note:** Manually added punches will show **bolded**.

Use the Employee List to select an employee and the pay period navigation buttons to select the Pay Period.

**See the PayClock Help for detailed information on using the Timecard Tab.**

### Selecting an Employee

To select and open an employee's timecard click on the desired employee in the list and their timecard will display.

### Selecting the Pay Period

Use the arrow  buttons on the Select Pay Period navigation bar of the Timecards tab to move forward or backward through the available pay periods until the desired time period is

displayed. You can also click the calendar  button which opens a window that allows you to choose from a list of pay periods.

### Adding Punches - Timecard Table

You can add punches from within the timecard table and by using the Insert button on the timecard table toolbar.

- Select the Timecards tab on the ribbon bar and click on the desired employee from the Employee List, the employee's timecard will display.
- Click on the In or Out cell for the day when you want to add a punch. The cell will be highlighted when it has been selected.
- Type in the hour and the cursor will automatically move to the minutes.
- Type in the minutes and the cursor will automatically move to AM/PM.
- If your time is set to 12-hour format type an 'A' or 'P' to change to AM or PM.
- Press enter or tab on the computer keyboard to save the punch.

### **Adding Punches - Insert Button**

You can use the Insert | Registration button to add a punch when there isn't an empty cell in the timecard table to key in a time.

- Select the Timecards tab on the ribbon bar and click on the desired employee from the Employee List, the employee's timecard will display.
- At the timecard table toolbar click the Insert button and select Registration, the Add Registration window will open.
- Type in the hour and the cursor will automatically move to the minutes.
- Type in the minutes and the cursor will automatically move to AM/PM.
- If your time is set to 12-hour format type an 'A' or 'P' to change to AM or PM.
- Enter the date for the punch.

- Click the Save and Exit button, the punch will be added to the timecard.

### **Adding Non-Work Time - Timecard Table**

You can add non-work time from within the timecard table and by using the Insert button on the timecard table toolbar.

- Select the Timecards tab on the ribbon bar and click on the desired employee from the Employee List, the employee's timecard will display.
- Locate the non-work time column and then click on the cell for the day that you want to add the non-work time. The cell will be highlighted when it has been selected.
- Type in the amount of hours and minutes for the non-work time; use the right arrow key to move from hours to minutes.
- Press enter or tab on the computer keyboard to save the non-work time.

### **Adding Non-Work Time - Insert Button**

You can use the Insert | Non-Work Time button to add a non-work time.

- Select the Timecards tab on the ribbon bar and click on the desired employee from the Employee List. The employee's timecard will display.
- At the timecard table toolbar, click the Insert button and select Non-Work Time. The Add Non-Work Time window will open.
- Enter the amount of non-work time at the Duration field, for example 8:00 for 8 hours.
- Select the pay code to apply the non-work time, for example vacation.
- Select the date to apply the non-work time.

- Click the Save and Exit button. The non-work time will be added to the timecard.

### **Adding Department Transfers - Timecard Table**

A department transfer is when an employee stops working in one department and then begins working in another department.

- Select the Timecards tab on the ribbon bar and click on the desired employee from the Employee List, the employee's timecard will display.
- At the timecard table toolbar click the Insert button and select Transfer. The Add Transfer window will open.
- Type in the hour and the cursor will automatically move to the minutes.
- Type in the minutes and the cursor will automatically move to AM/PM.
- If your time is set to 12-hour format, type an 'A' or 'P' to change to AM or PM.
- From the list, select the department for the transfer.
- Click the Save and Exit button, the transfer will be added to the timecard.

### **Making a One-Time department change in the Timecard Table**

You can make a one-time department change in an employee's timecard for a selected day or for a selected interval and keep all other days at their original department assignments.

If the Department column is displaying in the timecard table simply click in the cell for the desired day and from the list select the desired department. The department change will take affect immediately.

|  |
|--|
| <p><b>See the PayClock Help for detailed information on making a one-time department change in the timecard table.</b></p> |
|--|

### **Making a One-Time shift change in the Timecard Table**

You can make a one-time shift change in an employee's timecard for a selected day and keep all other days at their original shift assignments.

If the Shift column is displaying in the timecard table simply click in the cell for the desired day and from the list select the desired shift. The shift change will take affect immediately.

**See the PayCLOCK Help for detailed information on making a one-time department change in the timecard table.**

### **Adding Amounts - Insert Button**

You can use the Insert | Amounts button to add an amount to the timecard. An amount could be considered a dollar value for example \$25 in tips.

- Select the Timecards tab on the ribbon bar and click on the desired employee from the Employee List. The employee's timecard will display.
- At the timecard table toolbar click the Insert button and select Amounts. The Add Amounts window will open.
- Click the New button.
- Select the date to apply the amount.
- Select the pay code to apply the amount for example Tips.
- Enter the amount for example 25.00 for \$25 dollars.
- Click the Save and Exit button. The amount will be added to the timecard, if you have the Tips column visible the amount will display in the column.

### **Adding a Timecard Note**

The Timecard notes feature allows you to insert a text note for an employee on a specific day/date.

For example, John Doe called in sick on Monday so you might want to attach a note on John's timecard for Monday that he called in sick. Note: Timecard notes will also display on reports.

After a note is added a note symbol  will display on the date cell. To see the text of the note move the mouse over the symbol.

- At the Timecard toolbar click the Notes button, the Note Editor window will open.
- Enter the text for the note; up to 500 characters can be entered.
- Click the Save button, the note will be added and an icon  will display identifying a note is attached.

## Using the Exception Filter

Exceptions are events that occur where PayClock will notify the user. User action may be required to resolve some exceptions, for example a missing punch. Other exceptions may not require any user action.

The PayClock software will highlight the timecard cell in red when an exception is found. You can click on the exception symbol  and a list of the exceptions will display. It will look like this example.

|                      |  |          |          |          |        |         |
|----------------------|--|----------|----------|----------|--------|---------|
| 07/20/10 Tue         |  07:35 AM | 11:33 AM | 12:00 PM | 04:05 PM | 007:55 | 730-400 |
| Approve Arrived Late |  |          |          |          | 000:00 | 730-400 |
| Approve All          |  |          |          |          | 000:00 | 730-400 |

Once an exception is located you can approve or OK the exception if you wish. When an exception is approved you will see a green check  in the cell. It will look like this example.

|              |  |          |          |          |        |         |
|--------------|--|----------|----------|----------|--------|---------|
| 07/20/10 Tue |  07:35 AM | 11:33 AM | 12:00 PM | 04:05 PM | 007:55 | 730-400 |
|--------------|--|----------|----------|----------|--------|---------|

To see which exceptions are approved select the cell with the green check  and then click Exceptions | View Exceptions... button.

**Note:** You can also remove the approval for an exception from the View Exceptions button.



See the PayClock Help for detailed information on using the Exception Filter.

## Selecting the Exceptions

- At the timecard toolbar click the Exception  button and select Exception Filter, the Exception Filter window will open.
- Select the exception(s) you wish to view from the list. To view all exceptions click the Select All option.
- Click Save, your exceptions have been chosen.

## Searching for Exceptions

- After selecting the exceptions to track select the first employee in the Employee List.
- At the timecard toolbar click the Exception  button and select Next Exception. This scans through the timecards moving forward in the employee list looking for exceptions. To scan backwards in the employee list select Previous Exception.
- PayClock will highlight the timecard cell in red once an exception is found. You can correct or approve the exception. Then click **Next Exception** to continue searching for additional exceptions. If none are found PayClock will display the message “No Exceptions Found”.

## Exporting Data

The Export button of the Timecards tab allows you to export your data to payroll. When you click the Export button a window opens

with the exporting options you have setup at the Setup tab | Exports button.

The export process generates an export file in the format required by your payroll service and makes it available for your payroll software.

**See the PayClock Help for detailed information on exporting data.**

### Creating an export file

- Select the Timecards tab and select the pay period by using the Pay Period navigation buttons.
- Click the Export button, the Execute Exports... window opens.
- Click on the desired payroll export in the list, there will be a check in the box  when it has been selected.
- Click the Run Exports... button.

### Closing the Pay Period

The Close button group contains the button which allows the user to close out the pay period. The close process “locks” the timecard data and no edits can be made. **Note:** You can not close a pay period if other users are logged into the PayClock software.

After you close the pay period you can still run reports and exports but you cannot edit the closed data. Make sure that you have finished making all your changes before closing your pay period.

**Note:** A closed pay period can be re-opened for the purpose of making a forgotten edit but caution should be used. Payroll rules may have changed since the pay period was closed and once a pay period is re-opened it will be recalculated using the rules at the time of the re-open if changes are made to an employee’s timecard data.

**See the PayClock Help for detailed information on closing or re-opening a pay period.**

### Close the Pay Period

- Select the Timecards tab and click the Close button. The Select Pay Period window displays.
- Select the desired pay class and click OK.
- When the Close Procedures window opens verify that the dates for the pay period being closed are correct.

 **WARNING** - If you are not sure you want to close the pay period click **CANCEL**.

- Type the word **YES** in the box and click OK with your mouse.

### Re-opening a Closed Pay Period

A closed pay period can be re-opened for the purpose of making a forgotten edit or change, but caution should be used. Payroll rules may have changed since the pay period was closed and once a pay period is re-opened it will be recalculated using the rules at the time of the re-open if changes are made to an employee's timecard data.

**Important Note:** When you re-open a closed pay period all other open pay periods will be temporarily closed and will not allow edits. Once the re-opened pay period is closed again the temporarily closed pay periods will go back to their normal open state and will allow edits.

- Select the Timecards tab. Using the Pay Period navigation buttons locate the closed pay period to be re-opened.
- The Close button will change to a Re-Open button.
- Click the Re-Open button. When the Re-Open Procedures window opens verify that the dates for the pay period being re-opened are correct.

 **WARNING** - If you are not sure you want to re-open the pay period click **CANCEL**.

- Type the word YES in the box and click the OK button with your mouse.
- The Pay Period Status will change to “Open For Edit” and all others will change to Closed.

## Global Scheduling

The Scheduling tab presents a summary or snapshot of the estimated labor coverage in hours and dollars on a calendar. In addition the Scheduling tab is used to apply shifts to groups of employees, allowing shift assignments in mass rather than having to assign shifts to employees individually. These shift assignments will make up the employee's work schedule. You define the employee's work schedule in the calendar and assign shifts by date. A separate labor coverage chart is also available to view which allows for verification that there is enough labor coverage but not too much for a work day.

### Scheduling Summary

The Summary window of the Scheduling tab presents a summary view or snapshot of the estimated labor coverage in hours and dollars on a calendar. A separate labor coverage chart is also available to view which allows for verification that there is enough labor coverage but not too much for a work day.

### Global Shift Assignments

The Assign Shifts window of the Scheduling tab is used to apply shifts to groups of employees allowing shift assignments in mass rather than having to assign shifts to employees individually. These shift assignments will make up the employee's work schedule. You can define the employee's work schedule in the calendar and assign

shifts by date. A separate labor coverage chart is also available to view which allows for verification that there is enough labor coverage but not too much for a work day.

To make global assignments of shifts simply press the **Go to Assign Shifts View** button. The workspace will open allowing shift assignments by groups of employees. To view the labor coverage summary again simply press the **Return to Summary View** button.

**See the PayClock Help for detailed information on Global Scheduling.**

## Reports

The Reports tab of the ribbon bar is used to obtain reports on the information that is stored in the database. When you click on the Reports tab you will see 3 areas; the Report Ribbon Bar, the Report Category List and the Report Toolbar with Viewer.

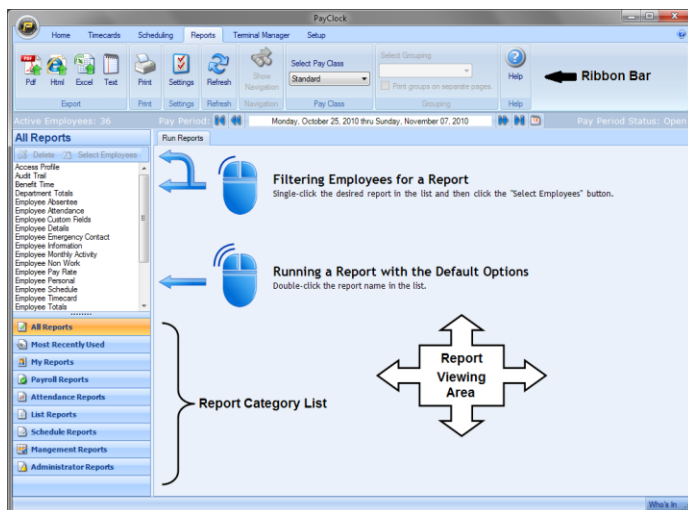

## Running Reports

The Reports tab is used to view reports on employee data. The Reports Ribbon Bar has the following button groups; Export, Print, Settings, Refresh, Navigation, Pay Class, Pay Period, Grouping and Help. You can run reports on the open pay periods, closed pay periods or for a date range. **Note:** Certain reports allow you to drill down to see more detailed information.

The Report Category List area is where you choose which report you want to display in the viewer. The list of available reports is populated when a report category is selected. The available categories are; All Reports, Most Recently Used, My Reports, Payroll Reports, Attendance Reports, List Reports, Schedule Reports, Management Reports and Administrator Reports.

### **Including All Employees in the selected report**

To view a report with all of the employees simply double click on the report in the list.

- Click the Reports tab on the ribbon bar and the Reports window will display.
- Double click on the report in the list you want to view.
- The report will show in the preview area with all employees.

### **Including certain Employees in the selected report**

To select certain employees to include on a report single click on the desired report in the list and then click the Select Employees button and choose the desired employees.

- Click the Reports tab on the ribbon bar and the Reports window will display.
- Single click on the report in the list you want to view.
- Click the Select Employees button and the Select Employees window will open.
- Select the employee(s) to include on the report and click Show Report.
- The report will show in the preview area with the selected employee(s).

### **Selecting the Pay Period for the report**

- Select and preview the desired report.
- Choose the pay period for the report by clicking the Pay Period navigation buttons. You can select any open or closed pay period.

|  |
|--|
| <p><b>See the PayCLOCK Help for detailed information on running Reports.</b></p> |
|--|

## Setting up your Terminal

The Terminal Manager tab of the ribbon bar is used to maintain the terminals used to collect punch data. When you click on the Terminal Manager tab you will see 3 areas; the Terminal Manager Ribbon Bar, the Terminals List and the Terminal Properties and Toolbar.

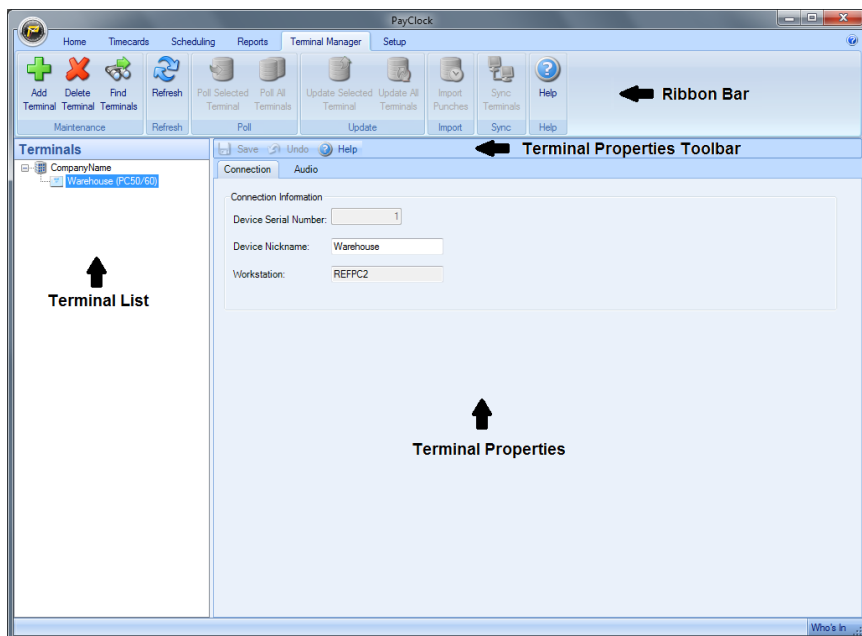

### The Terminal Properties and Toolbar

The Terminal Properties is used to view and edit the configuration of a terminal using seven tabs; Connection, Employees, Settings, Audio, Info, Update/Poll Schedule and Recovery.

#### PC60Terminal

The PC60 uses

See the PayClock Help for detailed information on the Terminal Manager tab.



## Hardware Troubleshooting

The following section contains common questions and problems as well as their appropriate resolutions.

To view a complete list of common problems and their solutions please visit our knowledge base located online at:  
<http://support.lathem.com>

| Issue  | Resolution  |
|--|---|
| <b>Does the computer have to be on all the time, with the USB terminal connected?</b>              | Yes. The USB terminal <b>must</b> be connected to the computer and the computer <b>must</b> be on in order for the USB terminal to be operational. The USB terminal will stop functioning when it is unplugged from the computer or when the computer is turned off.  |
| <b>The USB terminal stops operating when my computer goes into “sleep” mode. What should I do?</b> | The USB terminal will stop operating if your computer is set to go into the following:<br>-Sleep Mode<br>-Standby<br>-Suspend Mode<br>-Hibernation<br>Any of these settings should be disabled.   |
| <b>Can I use the USB terminal at any type of location?</b>   | No, you should avoid these types of locations:<br>-Locations that are exposed to extreme temperatures.<br>-Locations that are exposed to high humidity.<br>-Locations where condensation may occur due to sudden changes in temperature.<br>-Locations that are exposed to strong electric or magnetic fields, or in the vicinity of equipment such as TVs, radios, microwave ovens, and speakers.<br>-Locations where chemicals are stored or where exposure to chemicals is possible.<br>-Dusty locations.<br>-Locations that exposed to strong vibrations. |

|  |  |
|--|--|
| <p><b>When an employee tries to punch on the USB terminal, the display says “Server is offline”. What should I do?</b></p> | <p>The connection to the PayClock Database Service has been interrupted.</p> <ul style="list-style-type: none"><li>-Wait for the connection to re-establish itself. All punches will be saved and the punches will be added to the database when the connection is re-established.</li><li>-Check the network connections and repair as needed. You may need to contact your network administrator.</li><li>-Reboot the computer where the PayClock Database service is running. The PayClock Database service will restart automatically.</li></ul> |
|--|--|

## **Software Troubleshooting**

The following section contains common questions and problems as well as their appropriate resolutions.

To view a complete list of common problems and their solutions please visit our knowledge base located online at:  
<http://support.lathem.com>

| <b>Issue</b>  | <b>Resolution</b>   |
|---|---|
| <b>What is the password to login to the software?</b>   | The default password is "lathem".<br><br>If you have changed the default password, and can't remember your new password, contact the help desk for assistance in resetting your password. |
| <b>How do I add a missing punch?</b>                    | See page 53 - Maintaining Employee Timecards.   |
| <b>How do I export pay period data?</b>                 | See page 59 - Exporting Data.   |
| <b>How do I close a pay period?</b>                     | See page 60 - Closing the Pay Period.   |
| <b>How do I change PayClock to a multi-user system?</b> | See page 17 - Appendix A - Setting up a Multi-User System.  |

## Appendix A - PayClock Client Installation in a Multi-User System

Follow these instructions when you want to run PayClock on more than one computer. These client instructions apply whether it is a new install or an upgrade. The PayClock Server must be installed before installing the Client software.

**Note:** The multi-user license must be activated if you wish to access the PayClock software from different computers on your network. Additional license fees may apply. In order to activate the multi-user license, you will have to register your PayClock software first.

### □ Run the PayClock Setup Program

- Go to the computer where you want to install PayClock.
- Make sure your screen saver is not showing before inserting the PayClock CD.

|   |
|---|
| <b>XP   Vista   Windows 7   Server 2003   Server 2008</b> |
|---|

- Insert the **PayClock CD** into your computer's CD-ROM drive. **Note:** Click Allow or Yes at the User Account Control confirmation window.
- The Setup program should run automatically. If not, follow the steps below.
  - Click **Start | My Computer** or **Computer**.
  - Double click on the drive that contains the PayClock installation CD.

|                  |
|------------------|
| <b>Windows 8</b> |
|------------------|

- Click the message "Tap to choose what happens on the disk."
- Select Run Setup.exe. **Note:** Click Yes at the User Account Control confirmation window.

## ❑ Follow the Setup Steps

- It may take the install a few minutes to start, please be patient.
- From the Install PayClock window click on **Next**.
- Read the License Agreement and select **I accept the terms of the license agreement** and **Next** to move forward.
- Select the **Custom option** and click **Next** to continue.
- At the Install Client Only or Client & Server window, select **Client Only** and click **Next** to continue.
- At the Ready to Install screen, click **Next**.
- At the Installation Complete screen click **Finished**.

## ❑ Open PayClock

- After installing, you can run PayClock by clicking its icon. The default log in is Admin with the password 'lathem'.

## Appendix B - Integrating PayClock with QuickBooks

The integration between PayClock and QuickBooks allows the user to enter the employees into QuickBooks and then synchronize them into PayClock. The export process allows PayClock to send employee total daily hours into the QuickBooks weekly timesheet. Here are some important points to remember:

- Only QuickBooks 2009 and later are supported.
- QuickBooks and PayClock must be installed on the same computer.
- PayClock cannot export an output file that can be imported into QuickBooks

### Follow these steps to set up the integration between PayClock and QuickBooks

- Open QuickBooks in **Single User Mode** with Administrator access.
- With PayClock open, click the Setup tab.
- Click the Exports button, the Exports window will open.
- Click New and select Standard: QuickBooks 2009 or Later.
- Click the Setup Export button and the Export Wizard will open.
- Select the Pay Class desired and click Next.
- Click Next again and the QuickBooks Integrated Application window will open.
- Select **Yes, always; allow access even if QuickBooks is not running.**
- Check the option **Allow this application to access personal data such as Social Security Numbers and customer credit card information.**

**NOTE:** If the above two options are not selected the integration process will fail!

- Click Continue and then click Done.
- In PayClock click Next.
- Map the QuickBooks Payroll Items to the PayClock Pay Codes.
- When finished mapping the payroll items click Next.
- If desired select the Send Employee pay rates from QuickBooks to PayClock. Click Next.
- If Classes are set up in QuickBooks map the QuickBooks Classes to the PayClock departments. Click Next.
- Give the export a unique name if multiple pay classes are to be set up to integrate with QuickBooks. For example give it the name of the pay class it is linked with.
- Click Finish. PayClock will synchronize with QuickBooks and will display the Resolve Employee Conflicts window.
- At the Resolve Employee Conflicts window match QuickBooks employees to PayClock employees.
- Choose Create New Employee for any hourly employee not listed in PayClock.
- For salaried employees, choose Import as Inactive.
- Click Save.

Once the export is configured PayClock will automatically get any new employees or edited employees from QuickBooks when PayClock is opened.

At the end of the pay period click the Export button on the Timecard tab to send the pay data hours from PayClock to QuickBooks.

## Appendix C - PayClock Client Software WAN Installation

These instructions identify the steps to configure the PayClock Client software to communicate with the PayClock database server across the internet.

### Important Notes - WAN Installation Requirements

- There must be a VPN tunnel connecting the local and remote sites.
- The network administrator may be required to configure the network routers to route the ports used by the PayClock Client and PayClock database server.
- A static IP address is **required** on the computer designated as the PayClock database server.
- PayClock **must** be licensed as a “Multi-User” system, additional license fees may apply.

**Important Port Information** - The following ports are used for this type of installation.

- 7350 - PC600 Service
- 7351 - PC600 Auto Poll Service
- 2638 - PayClock Database Server

### Step #1 - Computer where the PayClock database server will reside

- Install the PayClock Server (Standard Install).
- Print out the “Server Summary” information. Note: If the “Server Summary” information was not printed during the installation follow these steps to access the information:
  - Open the PayClock software.
  - Click the PayClock orb on the upper left.
  - From the menu select **Support Assistant**.



- In the Support Assistant window, select **Connection Info**.
- Print the Connection\_Info.txt file.

## Step #2 - PayClock Client at the remote site

- **Run the PayClock Setup Program**
- Go to the computer where you want to install PayClock.
- Make sure your screen saver is not showing before inserting the PayClock CD.

### XP | Vista | Windows 7 | Server 2003 | Server 2008

- Insert the **PayClock CD** into your computer's CD-ROM drive. **Note:** Click Allow or Yes at the User Account Control confirmation window.
- The Setup program should run automatically. If not, follow the steps below.
  - Click **Start | My Computer** or **Computer**.
  - Double click on the drive that contains the PayClock installation CD.

### Windows 8

- Click the message "Tap to choose what happens on the disk."
- Select Run Setup.exe. **Note:** Click Yes at the User Account Control confirmation window.
- **Follow the Setup Steps**
  - It may take the install a few minutes to start, please be patient.
  - From the Install PayClock window click on **Next**.
  - Read the License Agreement and select **I accept the terms of the license agreement** and **Next** to move forward.
  - Select the Custom option and click **Next** to continue.

- At the Install on Single PC or Network window select **I need multiple computers that can run PayClock** and click **Next** to continue.
- At the Install Client Only or Client & Server window select **Client Only** and click **Next** to continue.
- **Enter the Server Information**
  - The **Select Server** window will open with the message, “We were unable to locate any PayClock servers on your network. Please enter the server information.”.
  - Enter the Database Server Name in the field. **Note:** Use the Server Summary or Connection Info print out for the PayClock database server’s name.
  - Enter the Database server’s IP address in the field. **Note:** Use the Server Summary or Connection Info print out for the PayClock database server’s IP address.
  - Click **Next** to continue.
  - At the Ready to Install screen click **Next**.
  - At the Installation Complete screen click **Finished**.

### Step #3 - Open PayClock at the remote site

- Open the PayClock software to verify the connection.

## **A**

Accessories, 3  
Adding a New Employee, 35  
Adding a Note, 49  
Adding Amounts, 49  
Adding Employees, 34  
Adding Non-Work Time, 47  
Adding Punches, 45, 46  
Annual Support Agreements, 4

## **B**

Badge Number, 35  
Benefit Time Tab, 38

## **C**

Closing the Pay Period, 52

## **D**

Department Tab, 38  
Department Transfers - Adding, 48

## **E**

Editing Timecards, 39  
Employee  
    PIN, 36  
Employee Advanced Tab, 38  
Employee Button, 34  
Employee List and Toolbar, 40  
Employee Number, 36  
Exception Filter, 50  
Exporting Data, 51

## F

Features & Specifications, 2  
Filtering the Employee List, 40

## G

Global Scheduling, 54

## H

Hardware Troubleshooting, 59  
Help, 3  
Home Department, 36  
**Home Tab**, 25

## I

Install the PayClock Software, 7  
Install the USB Terminal Manager Software, 9  
Integrating PayClock with QuickBooks, 64

## L

Logging In, 26

## M

**Maintaining**, 45  
Messages Tab, 38  
Minimum PayClock Set up, 29  
Mounting The PC50/60, 20

## O

One-Time Department Change, 48  
One-Time Shift Change, 49  
Overrides Tab, 37

**Overtime**, 30

## **P**

Package Contents, 5

Password, 27, 61

**Pay**, 30

PayClock Client Installation, 62

PayClock Client Software WAN Installation, 66

PayClock orb, 25

**PayClock Proximity Terminal - PC50/60**, 1

Personal Tab, 38

Product Overview, 1

Purpose of this User's Guide, 1

## **R**

Registering PayClock, 27

Re-opening a closed pay period, 53

Reports, 56

Reports Tab, 25

**Rounding**, 31

Running Reports, 56

## **S**

Salaried Employees, 36

Schedules Tab, 37

Scheduling Tab, 25

Searching for Exceptions, 51

Selecting an Employee in the Timecard, 45

Selecting Exceptions, 51

Selecting the Pay Period in the Timecard, 45

Setting the columns in the Employee List, 41

Setting the columns in the Timecard, 43

Setting up Multi-User, 15

Setting up PayClock, 29  
Setting up your Terminal, 58  
Setup Tab, 25, 32  
Setup the Pay Period, 29  
**Shift**, 31  
Software Troubleshooting, 61  
Supervisor Functions, 36  
System Requirements, 6

## T

Telephone Support, 5  
Terminal Manager Tab, 25  
Terminals Tab, 38  
Timecard Color Legend, 43  
Timecard Ribbon Bar, 39  
Timecard Timeline, 44  
Timecard Toolbar, 41  
**Timecards Tab**, 25  
Troubleshooting, 3

## U

Upgrades, 2  
USB Terminal Manager Only Installation, 16  
Using PayClock, 26  
Using the PayClock Software, 24  
Using the PC50/60, 23  
Using the Quick Search, 41  
Using the Ribbon Bar, 24  
Using the USB Terminals, 20, 23



# Annual Support Agreement



Protect your investment with a Lathem annual Support Plan...

- **Free updates and version upgrades**

While you are covered under the support plan, you will have availability to the latest versions of your software when they become available. New versions often have improved features designed to increase the functionality of the product, and make existing operations work easier.

**Without the support plan: Software upgrades must be purchased individually.**

- **Toll-free telephone support**

If you have any questions with the operation or support of your system, you will have access to a trained support representative via our toll free number. Our knowledgeable representatives are trained to answer your questions quickly and effectively, so you won't waste your time unnecessarily.

**Without the support plan: Customer support calls will be billed on a per incident basis.**

- **Next day shipping of exchange clock**

If your clock goes down, or is damaged, you can rest assured knowing that with a simple phone call, an exchange unit will be shipped out of our facility the next business day. This will dramatically reduce your "down time", allowing you to get back to business as usual, and process payroll on schedule.

**Without the support plan: You must send in your clock for repair to be returned up completion.**

- **Extended Warranty**

The support plan will extend the standard warranty that came with your product. While under warranty or this plan, your time clock will be covered for parts and labor to repair defects in materials or workmanship. If the problem with your clock is covered under this extended warranty, you can simply keep the exchange clock.

**Without the support plan: Parts and labor are billed at standard rates.**



For more information, visit [www.lathem.com](http://www.lathem.com) or call Lathem at 1-800-241-4990.

200 Selig Drive S.W. • Atlanta, GA 30336 Made in U.S.A

Copyright © 2010 Lathem Time Corporation. PayClock, Lathem and the Lathem logo are registered trademarks of Lathem Time Corporation. All rights reserved.  
Windows is a registered trademark of Microsoft Corporation.

[www.lathem.com](http://www.lathem.com)