

LT SERIES

User's Manual

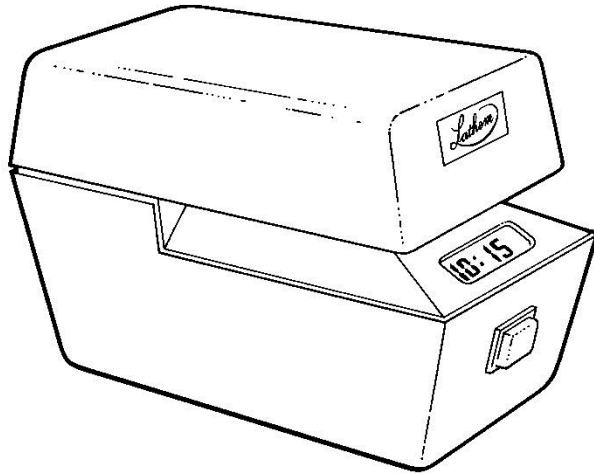

 **LATHEM**

TABLE OF CONTENTS

Specifications.....2
Introduction.....3
LT Series Models.....4
Optional Features.....4
Getting Started.....5
Installation5
Registration.....5
Setting the Type Wheels6
Setting the Digital Display.....7
Adjusting Print Impact.....8
Consecutive/Duplicate Count9
Adjusting the Registration Position.....10
Changing the Ribbon11
Changing the Fuse12
Changing the Platen.....13
Warranty14

WARNING: This equipment generates, uses, and can radiate radio frequency energy and, if not installed and used in accordance with the instruction manual, may cause interference to radio communications. It has been tested and found to comply with the limits for a Class A computing device pursuant to Subpart J of part 15 of FCC Rules, which are designed to provide reasonable protection against such interference when operated in a commercial environment. Operation of the equipment in a residential area is likely to cause interference, in which case, the user, at his own expense, will be required to take whatever measures may be required to correct the interference.

This document is a confidential proprietary document for the sole use of Lathem Time customers. The information contained herein may not be reproduced for any purpose without the written permission of Lathem Time Corporation.

SPECIFICATIONS

PHYSICAL

Height:	7 inches
Width:	5 1/4 inches
Depth:	11 inches
Weight:	12 3/4 pounds (standard models) 14 pounds (numbering models)
Case:	Impact Resistant Reinforced Lexan
Color:	Cool Gray
Power Cord Length:	6 Feet

COMPONENTS

Print Wheels:	Engraved Brass or Cast Zinc Alloy
Printing Platen Assembly:	Textured, soft surface for single copies.
Ribbon:	Purple Silk
Fuse:	3 Amp.
Digital Display:	LED
Timing Motor:	1 RPM, K342 type
Ribbon Drive Motor:	21 RPM, Model 60-3
Transformer:	12 VAC, 50/60 Hz 117 VAC (50/60 Hz 230 VAC Optional)
Numbering Solenoid:	110/120 VAC (220 VAC Optional)
Print Solenoid:	110/120 VAC (220 VAC Optional)

FEATURES

Print Impact Adjustment:	Variable, for multi-part forms
Time Format:	12-hour AM/PM 24-hour Continental Optional

POWER REQUIREMENTS

Voltage:	110/120 VAC (220 VAC Optional)
Current:	9 Amp. Max. Intrm. 110/120 VAC 4 1/2 Amp. Max. Intrm. 220 VAC
Frequency:	60 Hz (50 Hz Optional)

POSSIBLE SHOCK HAZARD EXISTS WHEN CASE COVER IS REMOVED AND AC POWER IS CONNECTED. USE CAUTION WHEN SETTING TYPE SECTION.

INTRODUCTION

The Lathem LT Series time stamps are considered "standard" by thousands of businesses and institutions because of their low initial cost and years of proven, trouble-free operation. The LT Series offers a wide variety of registration combinations that may be used for timing, numbering, and dating functions. The LT Series consists of four models, and is designed to meet virtually all of your validating needs. Standard features include: automatic registration; motor-driven ribbon shift for smooth, quiet operation; easy ribbon changing; registration position adjustment; and registration impact pressure control. Available options include a digital display, a manual registration button; allowing automatic or manual action, as well as repeat numbering. All units carry a full one-year factory warranty.



Lathem LT Series: Time, Date, and Numbering Stamps

Please read all directions carefully before operating or maintaining your LT Series unit. This operations manual is designed to provide basic operating instructions. Minor maintenance and adjustments may also be performed easily and effectively by referring to these instructions. For service beyond the scope of this manual, contact the dealer from whom you purchased the equipment, or Lathem Time Corporation. Should it be necessary to return the unit, retain the original packing materials for shipping.

LT SERIES MODELS

LTD

Registers date, month, and year. Type wheels must be advanced manually. Year wheels carry ten (10) years.

LTN

Registers consecutive numbers. Basic unit includes six (6) numbering wheels which advance automatically. Up to five additional numerical, letter, or code wheels may be purchased. The additional wheels must be advanced manually. (**Note:** The manual registration button is standard on this module.)

LTT(C)

Registers time, date, month, and year. Type wheels advance automatically. Month and date wheels must be reset manually the first day of each month. Models with a "C" designation have the optional digital display.

LTTN(C)

Registers time, date, month, and year, as well as consecutive numbering. The unit includes six (6) numbering wheels which advance automatically. Month and date type wheels must be reset manually the first day of each month. Models with a "C" designation have the optional digital display. (**Note:** The manual registration button is standard on this module.)

CONSECUTIVE/DUPLICATE COUNT

Models LTN and LTTN can repeat the same number once, twice, three times or four times before automatically advancing. (For jumper/shunt selection, see page 8, "Consecutive / Duplicate Count.")

OPTIONAL FEATURES

INSCRIPTION PLATES

The die plates may be permanently fixed or removable. They can have up to 3 lines of 20 characters per line, or carry facsimile signatures. (**Note:** Removable die plates must be removed *before* opening top frame and reinstalled *after* closing top frame.)

24-HOUR FORMAT

The digital display models (LTTC and LTTNC) can display 12-hour (standard), or 24-hour, also known as the Continental (0-23 hour), format, when specified at time of order. The time wheels can print 24-hour format for an added charge.

FIXED PAPER GUIDE

Provides a fixed edge on the side of the time stamp to help the user make more accurate registrations.

ADJUSTABLE PAPER GUIDE

Enables the user to position registrations more accurately on various paper sizes. Adjustments are made quickly and easily with the slide mechanism.

MANUAL REGISTRATION BUTTON [Standard on LTN and LTTN(C)]

Enables the user to position the document and manually activate the imprint.

GETTING STARTED

Getting started with the LT Series is easy. There are only a couple of fundamental decisions that must be made.

1. Plug the unit into the wall outlet.
2. Place the clock on top of the anti-skid rubber pad
3. Set the type section.
4. Set the digital clock (optional feature).

INSTALLATION

The LT Series time stamp installs easily on any tabletop or flat surface.

Determine whether you have a 110/120 VAC or 220 VAC unit, then plug it into any appropriate AC wall outlet. (**Note:** Avoid outlets with On/Off switches.

These outlets may be accidentally turned off, causing an interruption of the timing action.)

REGISTRATION

When forms are fully inserted into the stamp, an automatic trigger causes registration. If the optional manual registration button is installed, insert a form to the desired position by aligning the desired registration position with the print locators (Figure 1, Number 1) on the side of the case. When the form is aligned, press the manual registration button on the front of the unit (Figure 1, Number 2).



Figure 1

6 - LT Series Operations Manual

SETTING THE TYPE WHEELS

As noted in the earlier sections LT SERIES MODELS and OPTIONAL FEATURES, the LT Series Models are available with a variety of date, time, and number wheels. You may set the applicable type wheels according to the following directions.

1. **Disconnect the power source.**
2. Remove the top cover by inserting the key in the back of the unit, turning the key clockwise, and pulling the cover up and forward.
3. Remove the frame locking pin (Figure 2, Number 1). Lift the top frame (Figure 2, Number 2) to access time and date type wheels (Figure 2, Number 3) and number type wheels, if applicable.
4. Depress the time type setting lever (Figure 2, Number 4). Using a small screwdriver or similar tool, rotate each individual date and time type wheel down to the correct date and time. (**Note:** Month and date type wheels must be reset manually the first day of each month.)
5. Depress the number type setting lever (Figure 2, Number 5) and rotate the number type wheels (Figure 2, Number 6) to the correct position.
6. Close the top frame and insert the locking pin, positioning the pull ring down and inside the case. Reinstall the top cover, fitting the top securely into the grooves in the main frame case. Lock the top in place.
7. Connect the power source.
8. Make a registration to check for accurate date, time, and number readings. If necessary, reset the digital display. (See Page 7.)

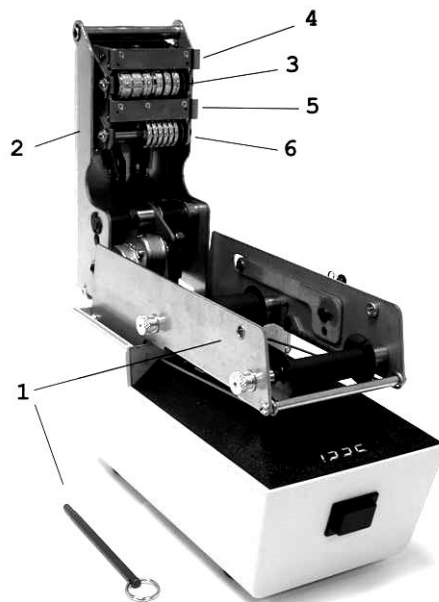

Figure 2

SETTING THE DIGITAL DISPLAY

Models with a "C" affixed to their designation (LTTC and LTTNC) denote units featuring a digital display. This display is factory-set for use in the 12-hour AM/PM format or the 24-hour (Continental) format. The digital display should always be synchronized with the time type wheels. To set the digital display and synchronize the display with the time type wheels, do the following:

1. Connect the power source.
2. Locate the three (3) push-buttons labeled SEC, HRS and MIN on the bottom of unit (Figure 3).



Figure 3

3. Return the unit to its upright position with the digital display facing towards you. Pull the unit forward slightly so the front hangs over the edge of the table, thereby giving you access to the buttons. (Remember: The minute button is on the right.)
4. Make a registration to see what time is indicated by the time stamp. Use the HRS (center) and MIN (right) buttons to set the time to the hour and minute indicated on the registration.
5. Place your finger on the minute button (right) but do not press it just yet. Listen for the type section to advance; you will hear an audible click. When you hear the click, immediately press the minute button to advance one minute. Seconds are now synchronized with the type section.
6. Make another registration to check the imprint feature for accuracy.

(Note: Interruptions in power lasting more than 3 to 5 seconds will cause the digital display to flash, indicating that it is necessary to reset the display.)

ADJUSTING PRINT IMPACT

Print impact may be set to any desired level, from very hard to very light. The impact adjuster is located on the bottom of the unit. Using a small flat head screwdriver, turn the adjuster to the right to increase or left to decrease the impact. (Figure 4)

(Note: To extend the effective life-span of the unit, use the lightest adjustment possible, which still gives a legible imprint.)



Figure 4

CONSECUTIVE/DUPLICATE COUNT (Numbering Units)

Units equipped with the numbering feature may be configured for *Consecutive Count*, advancing the number type wheel after each registration, *Duplicate Count*, advancing the number type wheel after every two registrations., *Triplicate Count*, advancing the number type wheel after every three registrations, or *Quad Count*, advancing the number type wheel after every four registrations. All units are shipped with the Consecutive Count mode enabled. Units having circuit board version “E” and above also support Triplicate and Quad numbering options. (See figure 6b).

To switch to Duplicate Count mode, **disconnect the power**. Locate and remove the Access Cover (Figure 4) using a Phillips-head screwdriver. The version of the Control Circuit installed is indicated on the product label, on the underside of the unit, as well as on the circuit board, itself. On version “D” circuit boards, the shunt is placed over 2 pins (Figure 6a). Remove the shunt and place it over just 1 pin. To return to the Consecutive mode, reverse the procedure. For units having circuit board version “E” and above, the DUP, TRIP, and QUAD numbering features are selected by positioning the shunt according to (Figure 6b).

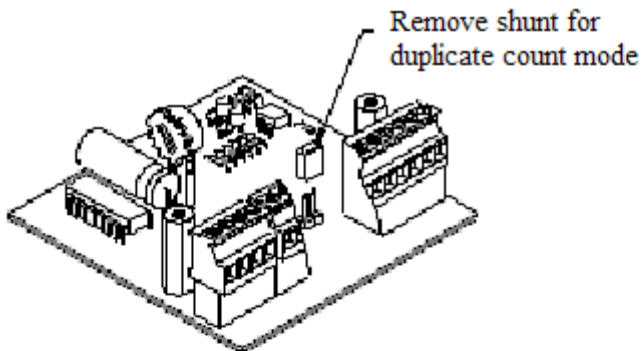

Figure 6a

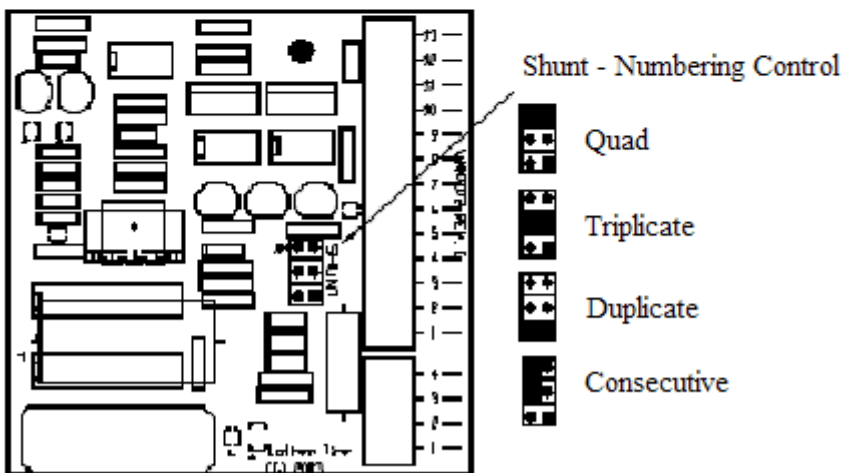

Figure 6b

ADJUSTING THE REGISTRATION POSITION

Depending on the type of document being stamped, it may be necessary to change the registration position. This can be accomplished by moving the trigger assembly. The trigger assembly has a range of motion of about two (2) inches forward or backward. The trigger assembly tells the unit how far the document must be inserted before activating the stamp. The print locators on either side of the top cover (Page 5, Figure 1, Number 1) can help you center the registration point.

To adjust the registration position:

1. **Disconnect the power source.**
2. Remove top cover and frame locking pin as described on Page 6. Lift the top frame.
3. Loosen the trigger adjustment screw (Figure 7, Number 1) and slide the trigger assembly (Figure 7, Number 2) to the desired position. (**Note:** Moving the trigger assembly towards you places the registration closer to the edge of the document. Moving the trigger assembly away from you places the registration farther from the edge of the document.)

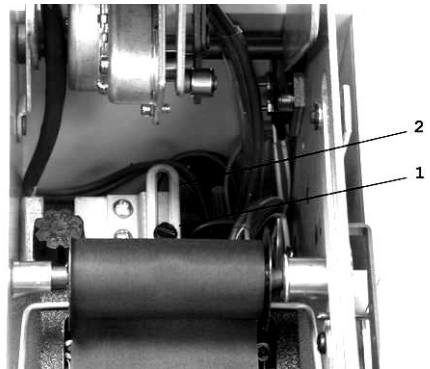

Figure 7

4. With trigger assembly in the desired position, tighten the trigger adjustment screw.
5. Close the top frame, install the frame locking pin, and replace the top cover.
6. Connect the power source.
7. Make a sample registration. If the registration is not in the desired location, readjust the trigger assembly by following the previous six steps. If the registration is in the desired location, reset the type wheels (see Setting the Type Wheels, Page 6) and the digital display (Setting the Digital Display, Page 7).

CHANGING THE RIBBON

LT Series time stamps use a silk ribbon for long-lasting, high-quality imprints. To avoid damaging the unit, use **only** a #20-S ribbon.

To change the ribbon:

1. **Disconnect the power source.**
2. Remove the top cover. Remove the frame locking pin and lift the top frame (as described on Page 6, Figure 2).
3. Pull the front spool plunger knob (Figure 8, Number 1) away from unit. While holding the knob, slide the ribbon to the left and out.
4. Release the spool plunger knob.
5. Repeat steps 3 and 4 with rear spool plunger knob. Remove and discard the used ribbon.
6. Pull the front plunger knob out and position the new ribbon as shown in Figure 8. Align the spool with the posts on the ribbon spindle shaft and the spool plunger (Figure 8, Numbers 2 and 1).
7. Release the spool plunger knob.
8. Repeat steps 6 and 7 with the rear spool plunger knob.
9. Close the top frame and install the locking pin. Install the top cover.
10. Connect the power source.
11. Make a sample registration. Reset the type wheels (Setting the Type Wheels, Page 6) and the digital display (Setting the Digital Display, Page 7).

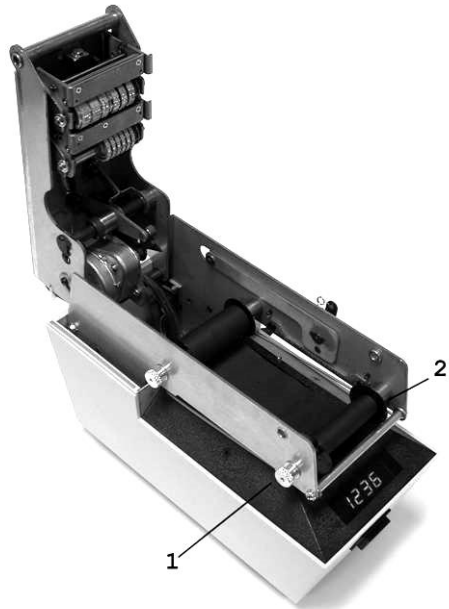

Figure 8

CHANGING THE FUSE

Each model of the LT Series comes equipped with a fuse. The fuse protects the unit from damage in case of a power surge or electrical overload. If too much power reaches the fuse, the fuse burns out, or is "blown," stopping operation of the unit and avoiding costly damage.

To change the fuse:

1. **Disconnect the power source.**
2. Remove top cover and frame locking pin as described on Page 6. Lift top frame.
3. Locate the Fuse Holder Cap (Figure 9, Number 1).
4. Remove the fuse cap by turning counterclockwise. Remove the old fuse.
5. Insert a 3 Amp replacement fuse (Type 3AG or equivalent). Press down on fuse holder cap and turn clockwise until it locks in place.
6. Close the top frame, install the frame locking pin, and install the top cover.
7. Connect the power source.
8. Make a sample registration. Reset the type wheels (Setting the Type Wheels, Page 6) and digital display (Setting the Digital Display, Page 7).

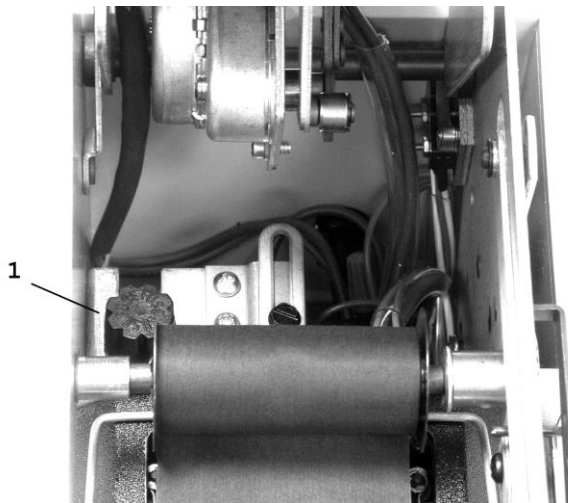

Figure 9

CHANGING THE PLATEN

1. **Disconnect the power source.**
2. Remove the top cover. Remove the frame locking pin and lift the top frame. Remove the ribbon (see Changing the Ribbon, Page 11).
3. Lift the printing platen assembly up and out of the frame. (Fig. 10)
4. Insert the alternate printing platen assembly, using the guide pin for alignment.
5. Replace the ribbon. Close the top frame and install the frame locking pin. Install the top cover.
6. Connect the power source.
7. Make a sample registration. Reset the time type wheels and the digital display.

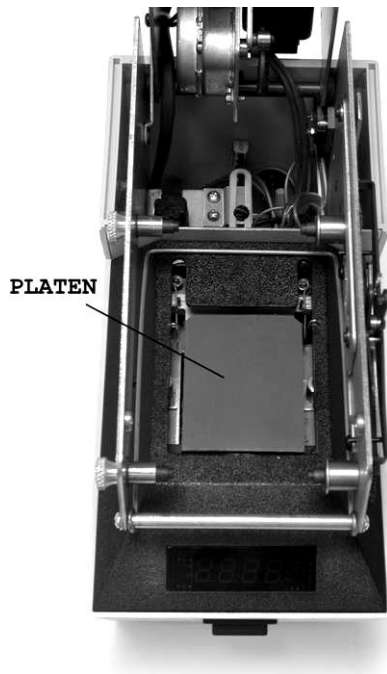

Figure 10

Limited One-Year Limited Warranty

Lathem warrants the hardware products described in this guide against defects in material and workmanship for a period of **one year** from date of original purchase from Lathem or from an authorized Lathem reseller. The conditions of this warranty and the extent of the responsibility of Lathem Time Corporation (“Lathem”) under this warranty are listed below.

1. This warranty will become void when service performed by anyone other than an approved Lathem warranty service dealer results in damage to the product.
2. This warranty does not apply to any product which has been subject to abuse, neglect, or accident, or which has had the serial number altered or removed, or which has been connected, installed, adjusted, or repaired other than in accordance with instructions furnished by Lathem.
3. This warranty does not cover dealer labor cost for removing and reinstalling the machine for repair, or any expendable parts that are readily replaced due to normal use.
4. The sole responsibility of Lathem under this warranty shall be limited to repair of this product, or replacement thereof, at the sole discretion of Lathem.
5. If it becomes necessary to send the product or any defective part to Lathem or any authorized service dealer, the product must be shipped in its original carton or equivalent, fully insured with shipping charges prepaid. Lathem will not assume any responsibility for any loss or damage incurred in shipping.
6. **WARRANTY DISCLAIMER AND LIMITATION OF LIABILITY:** Except only the limited express warranty set forth above, the products are sold with no expressed or implied warranties of any kind, and the implied warranties of merchantability and fitness for a particular purpose are hereby expressly disclaimed. No warranties are given with respect to products purchased other than from Lathem or an authorized Lathem reseller and any such products are purchased "as is, with all faults." In no event will Lathem be liable for any direct, indirect, special, incidental or consequential damages arising out of or in connection with the delivery, use or inability to use, or performance of this product. In the event any limited remedy given herein shall be deemed to have failed of its essential purpose, Lathem's maximum liability shall be to refund the purchase price upon return of the product.
7. Proof of date of purchase from Lathem or an authorized Lathem reseller is required for warranty service on this product.
8. This Warranty grants specific legal rights. Additional legal rights, which may vary by locale, may also apply.
9. Should any difficulties arise with the performance of this product during warranty, or with any Lathem authorized service centers, contact Lathem Time at the address below.

Lathem Time
200 Selig Drive, SW, Atlanta, GA 30336
404-691-0405

www.lathem.com

